

# KARAVAN

Enclosed are the operating instructions and warranty information for your new Karavan Trailer. Please review carefully before operating.

## OWNER'S MANUAL



BOAT



PERSONAL WATERCRAFT

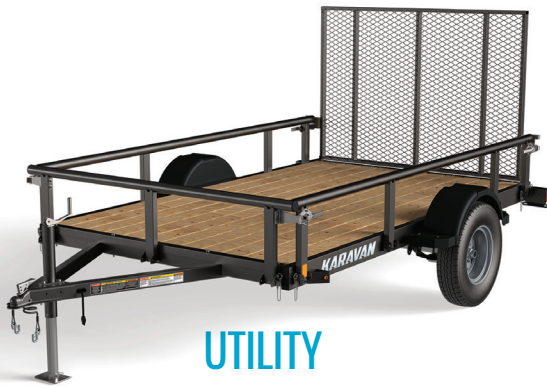

UTILITY



PONTOON



Product and specifications subject to change without notice.

**Karavan Trailers, Inc. Limited Warranty Policy**  
**Please register your trailer online at [www.karavantrailers.com](http://www.karavantrailers.com)**  
**A complete Owner's Manual is available online**  
**Contact us at: [warranty@karavantrailers.com](mailto:warranty@karavantrailers.com) or 920-928-6411**

**Karavan Trailers, Inc.** warrants each new **Karavan Trailers** trailer to be free from defects in materials and workmanship for a period of one (1) year from the date of purchase. **Karavan Trailers** shall repair or replace, without charge, any parts found to be defective because of imperfect workmanship or materials, within a reasonable time after the trailer is returned at purchaser's expense to any **Karavan Trailers** authorized distributor or dealer.

**Who is covered?**

This warranty is extended to the original purchaser only.

**How do I make a claim?**

1. Your claim must be filed on the Karavan website at: <http://www.karavantrailers.com> or in writing to: Karavan Trailers, Inc., 100 Karavan Drive, Fox Lake, WI, 53933.
2. Claim must provide true and complete information when filed.
3. You must cooperate with Karavan when attempting to resolve the claim.
4. Only Karavan and authorized dealers may be used to fulfill the warranty claim.
5. Karavan may elect to repair or replace your product, or in some cases, offer you a refund.
6. Karavan will inform you whether your claim is covered by warranty within thirty days of receiving the trailer.
7. Any disputes must be resolved in state or federal court.

**What is not covered?**

Although you may use the parts and maintenance, and repair services of your choosing, we recommend using authorized dealers and parts for any repairs or maintenance, because improper or incorrect use of parts, maintenance, or repairs will void this warranty. Authorized parts are recommended for replacement of winches, lights, couplers, brakes, tongue jacks, and springs. Authorized dealers are listed on the Karavan website.

The warranty will not cover defects or damage caused by unauthorized modifications or alterations.

The warranty does not apply to any defect or malfunction caused by damage, unreasonable use, or failure to provide reasonable and necessary maintenance.

The warranty will not cover damage caused by overloading the trailer beyond stated capacities or the use of improperly installed weight distribution hitches in conjunction with hydraulic surge brakes.

Rust formation is not covered because the trailer is exposed to highly corrosive conditions.

Tires are not covered. Warranty on tires shall be made through the nearest tire representative.

Bearing cups, bearings and seals are covered for 180 days from date of purchase.

The use of any unit as part of a rental fleet or use for commercial purposes voids this warranty.

**Other Limitations**

Any implied warranties, obligations, or liabilities including, but not limited to, any implied warranty of merchantability or implied warranty of fitness for a particular purpose, shall be limited in duration to the one-year duration of the written limited warranty.

**Karavan Trailers, Inc.** shall not be liable for incidental expenses of the consumer including, without limitation: loss of time, inconvenience, towing charges, travel expenses, lodging, telephone, gas, or loss or damage to personal property or loss of wages.

**Karavan Trailers, Inc.** shall not be liable for any incidental or consequential damages for breach of this or any other warranty expressed or implied.

This warranty gives you specific legal rights, and you may also have other rights which vary from State to State. Some States do not allow limitations on how long an implied warranty lasts, and/or the exclusion or limitation of incidental or consequential damages, so the above limitation or exclusion may not apply to you.

**Karavan Trailers, Inc.** will follow any controlling warranty laws for trailers purchased in countries outside the United States.

#### **Bow Eye Safety Chain**

**WARNING:** Failure to tie down the bow independently from the winch strap could allow your boat to shift while traveling, causing loss of control of the tow vehicle and result in serious injury or property damage.

Karavan Trailers, Inc. starts using bow eye safety chains on trailers with a 1200-lb winch rating and over. It is very important that you use the bow eye safety chain at all times when loading and unloading. The bow eye safety chain is an added protection should the winch or winch strap fail.

#### **Brakes**

In most states, trailers with a Gross Vehicle Weight Rating of 3,000 pounds or more are required by law to have brakes on all wheels. Upon special request, you can order axles with brake flanges to be able to install brakes. Brakes are becoming more of a necessity especially since the introduction of the small size car. Most trailer brakes are designed to operate automatically when the towing vehicle's brakes are applied. When the towing vehicle slows down or stops, the forward momentum of the trailer against the ball hitch applies pressure to a master cylinder in the trailer coupler. This pressure activates the trailer brakes through a hydraulic brake system.

**Caution:** Weight equalizing or sway control devices inhibit the performance of surge brake actuators and must not be used. Air shocks on the rear axle of the tow vehicle offer a good means of leveling the vehicle and trailer when necessary.

#### **Reporting Safety Defects**

If you believe that your vehicle has a defect that could cause a crash or could cause injury or death, you should immediately inform the National Highway Traffic Safety Administration (NHTSA) in addition to notifying Karavan Trailers, Inc. If NHTSA receives similar complaints, it may open an investigation, and if it finds that a safety defect exists in a group of vehicles, it may order a recall and remedy campaign. However, NHTSA cannot become involved in individual problems between you, your dealer, or Karavan Trailers, Inc.

To contact NHTSA, call the Vehicle Safety Hotline toll-free at: 1-800-327-4236 (TTY 1-800-424-9153), <http://www.safecar.gov>; or write to: Administrator, NHTSA, 1200 New Jersey Avenue S.E., Washington, DC 20590

You can also obtain other information about motor vehicle safety from <http://safecar.gov>.

# Warranty Information

If you experience any difficulties or defects with parts of the trailer please look for the manufacturers name on the part and contact them directly. The following is a list of Karavan's current vendors from whom parts are purchased.

Vendor	Phone #	Part
Dutton Lainson Co.	402-462-4141	Winches, Couplers
Badger Components	262-677-9381	Lights, Wire harness
CHYates	508-674-3378	Rubber Rollers
Auto Flex-Knott Inc.	920-928-6875	Actuators, Hubs, Torsion Axles, Blue Rollers, End caps, Keel Pads
UFP / Dexter	800-854-1905	Hubs, Brakes Drums, Actuator, Disc Brakes, Cables, Torsion Axle
TRP International	812-330-8749	Bearings & Seals
Emco Industries	918-342-3488	Springs
Tredit Tire & Wheel	800-887-3348	Tires
Kenda	800-0225-4714	Tires

## Table of Contents

### Item

---

Bow Eye Safety chain / Ball coupling / Brakes  
Models A-60, A-75 & a-84 Hydraulic Brake Actuator Owner's Manual & Users Instructions  
Disc Brakes Service Information (Trailer Buddy)  
Coupler Use: Maintenance, Installation, Service Information (DL)  
Hubs, Bearings, Seals and Adjustments  
Lighting and Wiring  
Changing Tire  
Tire Pressure  
Tire Safety Information  
Tire Warranty (Loadstar)(Carlisle)  
Towing your Trailer  
Tongue Jacks Installation Instructions (Cequent)  
Trailer Winch Operators Manual (DL)  
Auto Flex Warranty Info  
Registration/Warranty Cards

### Important

Read this manual carefully with special attention directed towards all WARNING, CAUTION and IMPORTANT information specially marked.

Because of the continual improvements being made in our line, Karavan Trailers, Inc., reserves the right to add or discontinue models at any time or to change design and specifications without notice and incurring obligations.

All specifications contained herein were in effect at the time this manual was printed.

Trailer laws covering such things as brakes, licenses, etc., will vary from state to state. Be sure that your trailer is in full compliance with your state laws. Your trailer dealer usually can help you in this regard. If not, contact your nearest state motor vehicle department office for full information.

The key to carefree trailering is a proper matching of the trailer to your needs. A proper match is one in which the total weight and size of the load you intend to haul falls under the capabilities that your trailer was designed and built to handle.

### Note

All references to the left or right are made when standing behind the trailer, facing the trailer.

## BALL COUPLING

**!** **WARNING:** The installed ball coupler **MUST** be properly secured to the hitch ball of the towing vehicle. After assembly and attachment, pull up and down on the ball coupler to make sure the hitch ball is fitting snugly on the hitch ball. There must be no play between the hitch ball and ball coupler. If there is play, tighten the adjustment nut until no play is present. If the adjustment nut is too tight, the handle will not lock.

If the ball coupler is not secured properly, it could come loose while the trailer is in motion, possibly causing property damage, **SERIOUS PERSONAL INJURY** or **DEATH**.

***CHECK BALL COUPLER TIGHTNESS OFTEN***

## Bow Eye Safety Chain

**WARNING:** Failure to tie down the bow independently from the winch strap could allow your boat to shift while traveling, causing loss of control of the tow vehicle and result in serious injury or property damage.

Karavan Trailers, Inc. starts using bow eye safety chains on trailers with a 1200-lb. winch rating and over. It is very important that you use the bow eye safety chain at all times when loading and unloading. The bow eye safety chain is an added protection should the winch or winch strap fail.

## Brakes

In most states trailers with a Gross Vehicle Weight Rating of 3,000 pounds or more, are required by law to have brakes on all wheels. Upon special request, you can order axles with brake flanges to be able to install brakes. Brakes are becoming more of a necessity especially since the introduction of the smaller size car.

Most trailer brakes are designed to operate automatically when the towing vehicle brakes are applied. When the towing vehicle slows down or stops, the forward momentum of the trailer against the ball hitch applies pressure to a master cylinder in the trailer coupler. This pressure activates the trailer brakes through a hydraulic brake system.

**CAUTION:** Weight equalizing or sway control devices inhibit the performance of surge brake actuators and must not be used. Air shocks on the rear axle of the tow vehicle offer a good means of leveling the vehicle and trailer when necessary.

**All disc brake trailers require your tow vehicle to have a 5 pin connector  
(show below)**

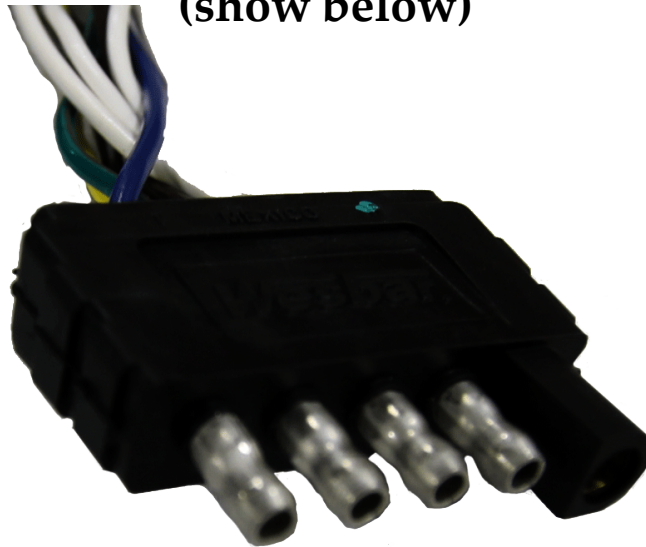

**!** **WARNING:** The warnings, cautions, and instructions discussed in this instruction manual cannot cover all possible conditions and situations that may occur. It must be understood by the operator that common sense and caution are factors which cannot be built into this product, but must be supplied by the operator

# OWNER'S MANUAL AND USER'S INSTRUCTIONS

## MODELS A-60, A-75 & A-84 HYDRAULIC BRAKE ACTUATORS

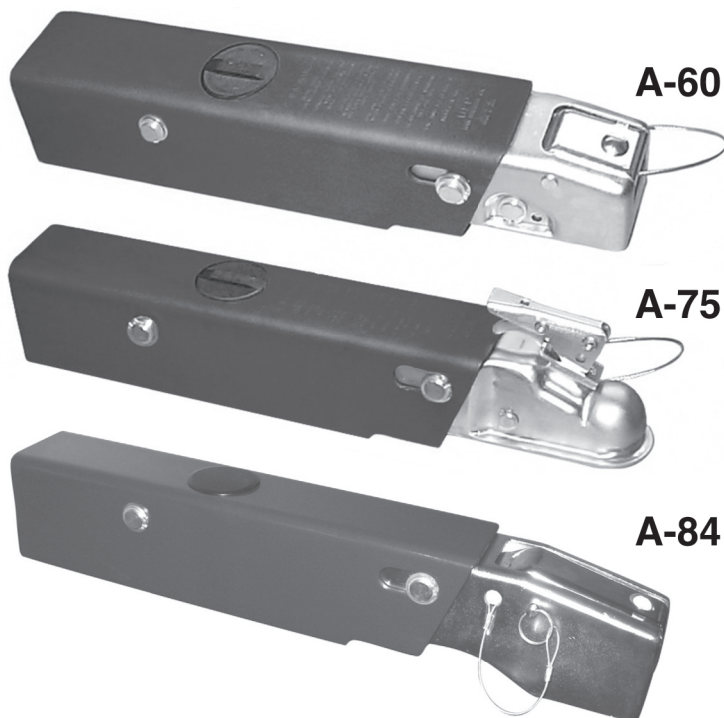

Breakaway cable clips



See installation instructions  
in this manual

WARNINGS .....	8
INTRODUCTION .....	8
HOW TO INSTALL THE ACTUATOR .....	10
TOWING REQUIREMENTS - EQUIPMENT .....	10
HOW TO ATTACH THE TRAILER.....	12
SAFETY CHECKS BEFORE TOWING .....	15
BACKING.....	17
PARKING AFTER USE .....	18
PERIODIC INSPECTION AND MAINTENANCE .....	19
EXTENDED STORAGE MAINTENANCE .....	21
BRAKE ADJUSTMENT .....	22
TROUBLESHOOTING BRAKE PROBLEMS .....	23
HOW TO TAKE APART AND ASSEMBLE THE ACTUATOR .....	26
MANUAL BLEEDING OF THE BRAKE SYSTEM .....	31
HOW TO INSTALL THE BREAKAWAY CABLE CLIP ..	33
DEFINITIONS.....	34
PARTS LIST .....	35
WARRANTY .....	37

# WARNINGS

THROUGHOUT THIS MANUAL, THE FOLLOWING SIGNAL WORDS AND SYMBOLS ARE USED TO ALERT YOU TO POTENTIAL HAZARDS. OBEY ALL MESSAGES AND INSTRUCTIONS. FAILURE TO FOLLOW THESE MESSAGES AND INSTRUCTIONS MAY LEAD TO POSSIBLE INJURY OR DEATH.



**DANGER** indicates an imminently hazardous situation which, if not avoided, will result in death or serious injury.



**WARNING** indicates a potentially hazardous situation which, if not avoided, will result in death or serious injury.



**CAUTION** indicates a potentially hazardous situation which, if not avoided, may result in minor or moderate injury.



**CAUTION** used without the alert symbol indicates a potentially hazardous situation which, if not avoided, may result in property damage.

# INTRODUCTION

Your trailer is equipped with the Model A-60, A-75 or A-84 Hydraulic Brake Actuator. Trailer brakes will automatically apply whenever the tow vehicle's brakes are applied. They will develop stopping (deceleration) force in direct proportion to the stopping force generated by the tow vehicle.



This actuator should only be installed on trailers with a Gross Vehicle Weight Rating (GVWR) of 6000 lbs. or less (A-60), or GVWR of 7500 lbs. or less (A-75), or GVWR of 8400 lbs. or less (A-84).



The A-60 & A-75 actuators are designed for use with a 2" hitch Ball. The hitch ball and tow vehicle must be rated to handle the actual Gross Vehicle Weight (GVW) of the trailer and load. A-84 actuator is designed for use with a 2 5/16" ball.

## ACTUATOR

The Model A-60 actuator maximum load rating is 6000 pounds, the maximum load rating for A-75 is 7500 pounds and the maximum load rating for A-84 is 8400 pounds. Models can support a maximum static tongue load of 750 pounds (A-60 & A-75), or 840 pounds (A-84). The maximum load rating is for the total weight of the trailer and boat fully loaded including all gear and includes tongue weight.

Read and familiarize yourself with this handbook. Also, review and understand the guidelines and requirements for towing published by the tow vehicle manufacturer and the trailer manufacturer.

Keep this handbook in your tow vehicle or with your trailer for future reference. Contact your dealer or our customer service department if additional information is desired.

You the user are responsible for the consequences of inadequate maintenance, deliberate misuse, alteration or damage to the actuator.



Trailer braking is controlled by the actuator mounted on the tongue of the trailer. When the tow vehicle brakes are applied, the “surge” or “push” of the trailer toward the tow vehicle automatically applies and synchronizes the trailer brakes with the tow vehicle brakes. The coupler slides into the actuator applying force to a piston inside of a master cylinder, which applies the trailer brakes.

### HOW THE ACTUATOR WORKS

At constant speed, the brake actuator master cylinder piston is in the free (extended) position; and the trailer brakes are not applied. The shock absorber controls random application of the trailer brakes when towing on rough roads. See Figure 1.

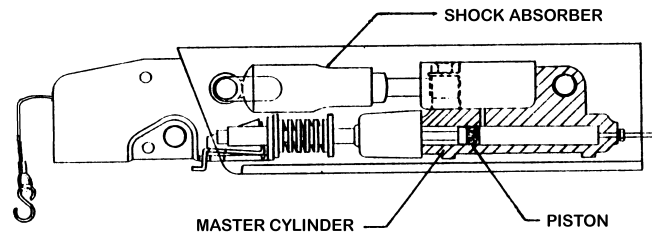

CUTAWAY VIEW

**FIGURE 1: ACTUATOR EXTENDED (RUNNING POSITION)**

When the tow vehicle slows down, the trailer moves toward the tow vehicle. The actuator slides over the coupler, applying force to the master cylinder piston in direct proportion to how fast the tow vehicle is slowing and how much the trailer weighs. The piston moves into the master cylinder, building pressure to apply the trailer brakes. The shock absorber makes sure the brakes are applied and released smoothly. See Figure 2.

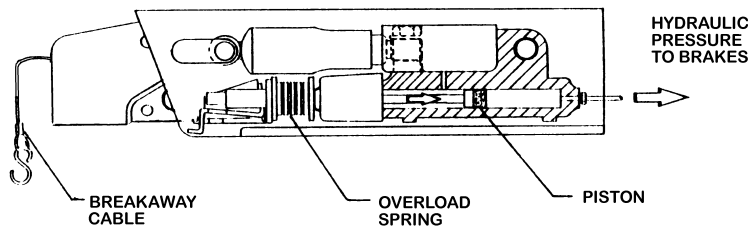

**FIGURE 2: ACTUATOR COMPRESSED (STOPPING)**

**NOTE:** You may notice a slight clunk when accelerating from a dead stop or anytime after braking, which is normal due to the nature of surge brakes. Contact your dealer or UFP if the clunk becomes excessive, or if you have any concerns about the performance of your brake system.

### TRAILER BREAKAWAY SYSTEM



All actuators must have a way to apply the trailer brakes should the trailer become completely detached from the towing vehicle. The breakaway cable is the third line of defense after trailer separation. Before the breakaway cable is pulled, the coupler must become detached from the hitch ball and then the safety chains must fail. At this time the breakaway cable is pulled which will apply a braking force to the trailer. Note: The breakaway system is not intended to lock up the trailer brakes after tow vehicle separation but rather to apply just enough braking force to keep the trailer from free-wheeling down the road. The breakaway system must be reset manually after it has been activated.

**DO NOT USE THE BREAKAWAY SYSTEM AS A PARKING BRAKE.**

# HOW TO INSTALL THE ACTUATOR

The actuator is to be used only with brakes specifically designed for trailer service. It should not be used with any custom built, one-of-a-kind brakes because such combinations have not been tested and evaluated. The actuator is designed for use with one or two sets of either 10" or 7" drum breaks. It can also be used with one set of 8 1/2" or 12" drum brakes. The basic actuator may be used with one set of UFP 10" disc or 12" disc brakes. A special version is available for operating 2 sets of 8 1/2" drum brakes and 2 sets of UFP 10" disc brakes. Contact factory for further information.



Some trailers do not have adequate brakes for the trailer, how it is used, or where it is towed. Not having adequate trailer brakes will increase stopping distance and cause more lining wear or overheating on your vehicle and trailer. You may wish to discuss this subject with your trailer dealer.

## TOWING REQUIREMENTS - EQUIPMENT



You must match the tow vehicle and trailer. Also make sure the hitch, hitch ball, and safety chain ratings match or are greater than the trailer Gross Vehicle Weight Rating.

### TOW VEHICLE

Review the tow vehicle owner's manual and trailering guide for information on towing capacity, requirements for brakes, use of weight-distributing hitches and other towing recommendations. Make sure your vehicle combination complies with the Gross Combined Weight Rating (GCWR) limits specified by the tow vehicle manufacturer.

### BRAKE LAWS

Brake laws vary from state to state. Be sure you understand and comply with regulations. Make sure your vehicle combination has adequate brakes and keep them properly adjusted and in good working condition. Brake laws usually set minimum standards. You may wish to consider a better braking capability depending on the tow vehicle, miles driven and towing terrain.

### HITCH

The tow vehicle's hitch must have a rating equal to or greater than the trailer GVWR.

### HITCH BALL

The hitch ball must have a rating equal to or greater than the trailer GVWR. Use only a quality machined, or forged ball, with a smooth finish. The A-60 & A-75 actuator coupler will only accept 2" diameter balls. Make certain a 2" diameter ball of the correct load rating is used. Balls must be within the limits of 1.970" - 2.000" diameter when measured in all directions. Balls larger than 2.000" or out of round will not fit the coupler socket. Balls smaller than 1.970" can cause shock loading and a sudden disconnection could result at worse case. The A-84 requires a 2 5/16" hitch ball with a rating equal to or greater than the trailer GVWR. The 2 5/16" ball must be within the limits of 2.282" - 2.312" diameter when measured in all directions. Hitch balls may be purchased from your dealer or UFP.

## HITCH HEIGHT

For proper tow vehicle and trailer hookup and towing performance, the tow vehicle and trailer are to be level with respect to the ground after hitching up. If your trailer is not level, equipment is available to raise or lower the hitch ball. A weight equalizing hitch or load support suspension equipment may also be required to keep the tow vehicle level and to properly load each axle.

## SAFETY CHAINS

Adequate safety chains must be used and conform to the Society of Automotive Engineers (SAE) J684 standard, "TRAILER COUPLING AND HITCHES - AUTOMOTIVE TYPE".



The strength rating of EACH length of safety chain must be equal to the trailer GVWR.

Make sure that your safety chains are fastened to the frame of the trailer and to the hitch or tow vehicle frame. Safety chains fastened directly to the hitch ball or to the bumper, are not acceptable and will not pass vehicle inspections. Connect safety chains using a crossed pattern under the tongue.

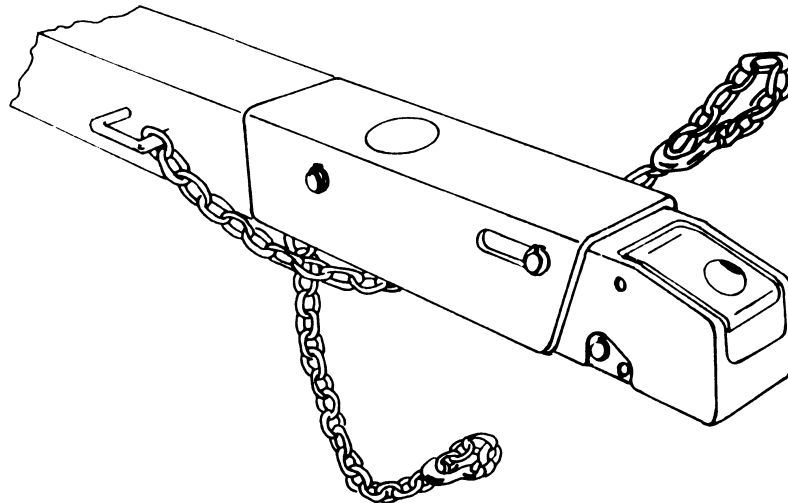

FIGURE 3 TYPICAL DOUBLE SAFETY CHAIN INSTALLATION

## SWAY CONTROL DEVICES



Trailer sway control devices that restrict operation of the actuator **MUST NOT** be used. These devices can limit the how much the trailer brakes work.

The coupler must be able to slide freely into and out of the actuator when your vehicle slows down.

## WEIGHT DISTRIBUTING HITCHES

Weight distributing (equalizing) hitches may be used. Chain must be vertical (straight up and down) under pulling load (actuator extended). Excessive tongue weight beyond actuator rating must be avoided as it will reduce brake performance and could damage the actuator. Always follow hitch and weight distributing manufacturer's instructions.

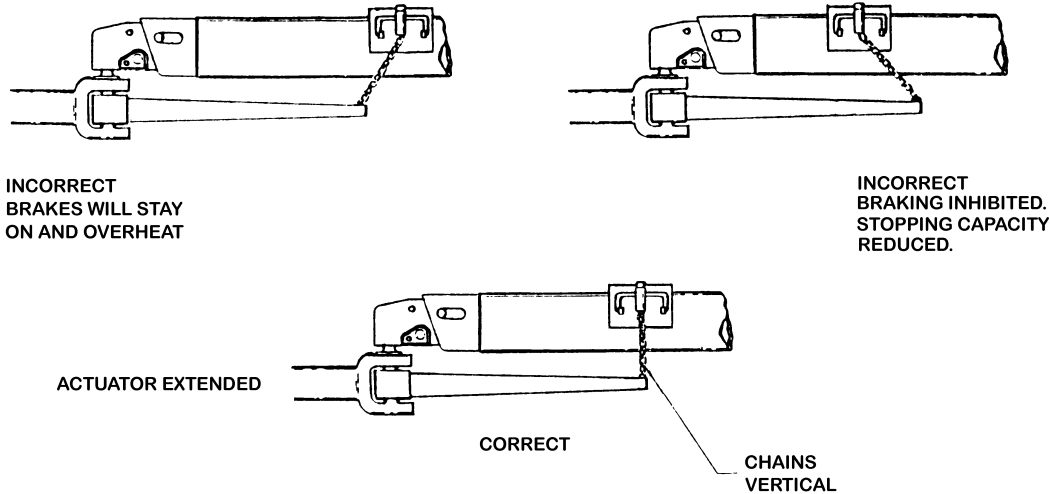

FIGURE 4 TYPICAL WEIGHT DISTRIBUTING HITCH INSTALLATION

## HOW TO ATTACH THE TRAILER

To connect the trailer to the tow vehicle, open the coupler mechanism (see instructions below) and if necessary, raise the trailer jack. Slowly back up the tow vehicle so that the hitch ball is under the coupler.

### **WARNING**

Do not move the trailer to the tow vehicle. When the trailer is moved without a tow vehicle, the brakes do not work.

If the latch accidentally opens, the coupler could detach from the hitch ball. The hitch pin should fit easily into the hole (Figure 5). If it does not, the coupler latch is not completely closed. Every time the coupler is attached to the hitch ball, make sure the coupler completely covers the hitch ball and the lift handle will not open without pushing the push button to the side (A-60) & (A-84) or pulling up on the trigger (A-75). If the hitch pin is damaged or lost, contact UFP for a free replacement pin.

### **WARNING**

You must install either the hitch pin (supplied) or a padlock (1/4" or 5/16" shank) into the hitch pin hole before towing to prevent the coupler latch opening accidentally. See figure 5.

### TO OPEN THE COUPLER (A-60) & (A-84)

Remove hitch pin from hole in the side of the coupler. Push button on top of handle to the side. While holding button to the side, raise handle by lifting front with two fingers. The coupler should unlatch easily. If not, the ball may be oversized or eggshaped, foreign matter could be lodged in coupler ball socket, or the coupler is pushing on the hitch ball. Check to make sure the wheel on the tongue jack is raised or that you are not parked downhill. Correct these conditions, then try to open the handle. Examples include tongue jack forcing front of trailer up or trailer pushing against tow vehicle. Correct as necessary.

### TO CLOSE COUPLER (A-60) & (A-84)

Place coupler over the ball, lower coupler and close handle. You will hear a “click”. Handle should close with finger pressure. If handle will not close freely, ball is not fully inserted into socket, is oversized or eggshaped. **DO NOT FORCE HANDLE.** If necessary, replace ball with a quality unit that meets SAE specifications. Insert hitch pin into hole on side of coupler.

### TO OPEN THE COUPLER (A-75)

Remove hitch pin from hole on side of coupler latch handle. While lifting up on latch handle trigger, lift up on latch handle until it rotates about 90 degrees and stops. The coupler should unlatch easily. If not, the ball may be oversized or egg-shaped, foreign matter could be lodged in coupler ball socket, or the coupler is pushing on the hitch ball. Check to make sure the wheel on the tongue jack is raised or that you are not parked downhill. Correct these conditions, then try to open the handle. Examples include tongue jack forcing front of trailer up or trailer pushing against tow vehicle. Correct as necessary.

### TO CLOSE COUPLER (A-75)

Place coupler over the ball, lower coupler and close handle. Coupler handle should close with minimal force. If handle dose not close, ball is not fully inserted into socket, is oversized or eggshaped. **DO NOT FORCE HANDLE.** If necessary, replace ball with a quality unit that meets SAE specifications.

Visually verify that ball is completely inserted into coupler socket by looking into hole on top of coupler body. Insert hitch pin into hole on side of coupler latch handle.

A-60

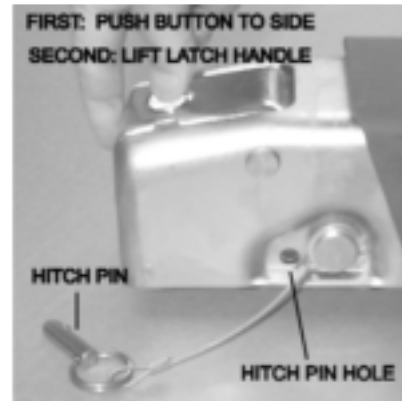

A-75

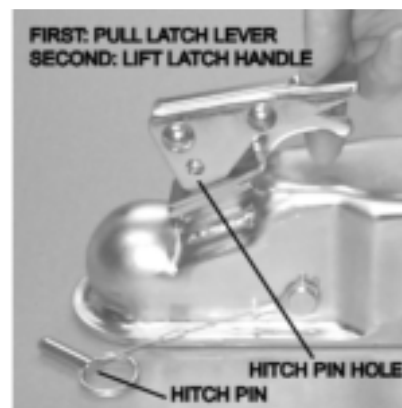

A-84

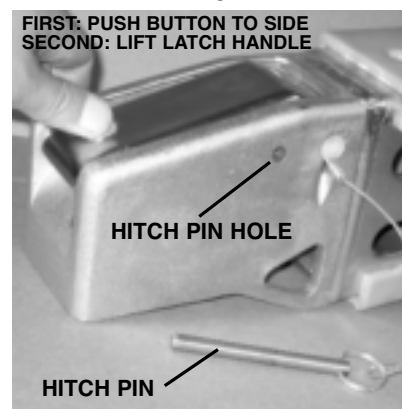

FIGURE 5  
OPENING COUPLER



You must install either the hitch pin (supplied) or (A-60 & A-75 only) a padlock (1/4" or 5/16" shank) into the hitch pin hole before towing to prevent the coupler latch opening accidentally. See figure 5.

**⚠ WARNING**

DO NOT tow your trailer if latch handle will not remain closed or with the handle open. Check to see if coupler is locked by lifting up on the handle without pushing the button to the side before towing. If the

handle opens, the hitch ball is not the right size, oversized, or eggshaped, or the latch parts have been damaged. If the latch is damaged, contact UFP for replacement parts.

**BREAKAWAY CABLE**

Secure the breakaway cable to the bumper or frame of tow vehicle as close to center as possible (do not attach to safety chains). The cable **MUST** hang clear of the trailer tongue and be long enough to permit sharp turns without pulling the cable and will not be applied unless the safety chains fail. Do not loop S-hook over breakaway cable to attach it.

**⚠ WARNING**

Never tow a trailer without the breakaway cable secured to the tow vehicle.

If the breakaway is accidentally pulled and the brakes applied, find out why this happened and fix the problem. Inadvertent setting of the brakes by pulling the breakaway cable is the single most common mistake users make. To prevent light pulls from accidentally setting trailer brakes, a small metal clip has been installed on breakaway cable in front of the indicator bead (A-60 & A-75 only). The clip will not inhibit the action of the breakaway mechanism during actual breakaway conditions. However, if breakaway should occur the clip will be destroyed and should be replaced. Spare clips are attached to the cover of this manual.

To retract the breakaway cable, slide the coupler fully forward and push up on the pushrod release bracket located on the underside and behind the hitch ball socket to allow the bead to retract into the actuator. This will release the trailer brakes. Install new clip on breakaway cable in front of bead.

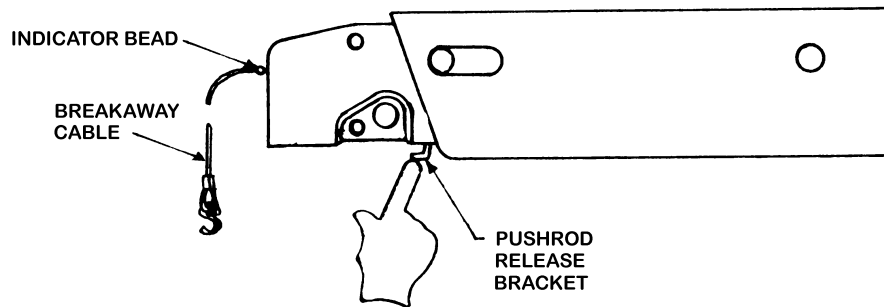

**FIGURE 6 CHECKING AND RESETTING BREAKAWAY CABLE**

If pushing up on the bracket does not release the brakes or if it is hard to push, insert a pry bar into the 5/16" hole behind the bracket. Use pry bar to stroke push rod backwards to relieve load on bracket. Push up on bracket and hold up while releasing pry bar. The pushrod release bracket should now move freely and brakes should be released. (figure 7)

Check to see if the actuator is reset. Extend the actuator fully. Remove the cap from the top of the actuator and pull the plug from top of the reservoir cover. While looking at fluid in the reservoir, manually compress actuator. In the first 1/8" of coupler movement the fluid in the reservoir should "splash" or "ripple" slightly. If it does, the actuator is working properly.

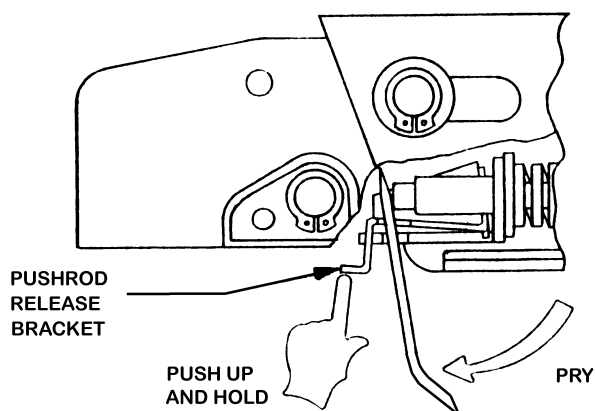

**FIGURE 7 STROKING THE PUSHROD TO RELEASE BRAKES**

**Note:** If brakes can not be released using above method or if pushrod release bracket will not move, it is damaged beyond serviceability. Contact UFP for repair parts.

## **SAFETY CHECKS BEFORE TOWING**



**WARNING**

**FAILURE TO READ AND FOLLOW THESE INSTRUCTIONS MAY RESULT IN SERIOUS INJURY OR DEATH.**

### **ACTUATOR CONDITION**

Check the actuator and coupler for damage, bent parts, and excessive wear. Replace parts if needed. Contact UFP for replacement parts. Check that the bolts that attach the actuator (if equipped) to the trailer are tight.



**WARNING**

### **COUPLER**

Check that the coupler (latch) handle closes (down) completely when the hitch ball is in the coupler. To make sure the coupler is secured to the hitch ball,

look under the coupler and check. Also, while the coupler is attached, raise the front of the trailer 2" to 4" with the tongue jack. If the coupler stays connected, it is secure. If coupler dose not stay attached try the attachment and attachment check again. If coupler will not stay attached to hitch ball, or latch opens inadvertently, **DO NOT TOW TRAILER – CONTACT UFP.**

### **REMEMBER TO LOWER TRAILER/RAISE JACK BEFORE TOWING.**

**Note:** At times the coupler can push on the hitch ball when parked. Check to make sure the tongue jack is raised or that you are not parked downhill. Correct these conditions, then try to open the handle.



**WARNING**

### **TONGUE WEIGHT**

It is very important your trailer have 5% to 10% tongue weight when it is loaded and the tongue is level. For example, a trailer weighing 4,000 pounds

**MUST** have a tongue weight of at least 200 pounds. This will help reduce trailer from swaying from side to side ("fishtailing"). A bathroom scale can be used to find the tongue weight of the trailer.

Not having enough tongue weight can cause the trailer to sway from side to side and the coupler to rattle up and down as you go down the road. This is very important and if the tongue weight is not in the 5% to 10% range, you should move the cargo (gas tank, anchor, fishing tackle, cooler) from the back to the front or back to front to make sure the tongue weight is in the range. On some trailers, the axle or axles can be moved to change the tongue weight.



#### **BREAKAWAY CABLE**

Check the breakaway cable each time before you tow and at gas and rest stops to make sure it has not been damaged. Check the location of the indicator

bead and clip. The clip should be in place (A-60 & A-75 only) and the bead should not be outside the actuator. Accidental application will cause brakes to drag and heat up.



#### **SAFETY CHAINS**

Make sure that your safety chains are secured to the tow vehicle per the instructions supplied by trailer manufacturer. SAE recommendations are listed in “Requirements-Equipment” section.



#### **FLUID LEVEL**

Check the fluid in the master cylinder reservoir each time before you tow or if you see break fluid leakage. Refill as required.



#### **HITCH BALL**

Make sure a hitch ball of proper size and correct load rating is used. A film of clean grease on the ball will extend coupler and ball life and stop squeaking. Wipe ball clean and renew film periodically.



#### **TOW VEHICLE HITCH**

The hitch on the tow vehicle must be of the proper load rating and in good condition. If hitch is of the receiver type, make sure receiver pull pin is in place and safety pin is installed.



#### **TRAILER JACK**

Trailer jack must be fully retracted and caster wheel removed (if necessary) before towing.



#### **AUTOMATIC BRAKE LOCKOUT (if equipped)**

The electrical lead from the solenoid valve must be connected to the tow vehicle backup lights. A “click” should be heard when the tow vehicle is shifted into reverse and the backup lights come on.

To check: Have someone listen for the sound while driver is in the tow vehicle. Keep the emergency brake on and one foot on the brake pedal to avoid accidentally backing up.



#### **ELECTRICAL WIRING**

Plug in connector and check signal, brake and running lights.



# BACKING

When you back your car and trailer, the coupler will move back and apply the trailer brakes. The brakes will apply at different levels depending on how fast you back up, the type of brakes, the road or surface you are on, and the angle of your trailer. If your trailer has drum brakes, most of the time the trailer brakes won't be a problem when backing up. Below are options that help you back up with the trailer brakes.

Some trailers with disc brakes need an electrical solenoid control to allow the trailer to back up. This control is wired th the back up lights on the tow vehicle and when the tow vehicle is put into reverse, this control dose not allow the trailer brakes to apply.

## BRAKE LOCKOUT BRACKET

A simple lockout is included on some models to stop the coupler from moving back when you back the trailer. The brake lockout bracket is used when you need to back over soft ground or up a hill. Use it as follows:

1. Put or place the brake lockout into slot behind roller pin on the side of the actuator.
2. Slide the brake lockout completely forward in slot. Washer will keep brake lockout from falling out while backing up.

When you pull the trailer forward and the actuator extends, the brake lockout should fall out of the slot. This makes sure the actuator will function when stopping.



**THE BRAKE LOCKOUT BRACKET MUST BE REMOVED BEFORE TOWING OR THE TRAILER BRAKES WILL NOT WORK.**

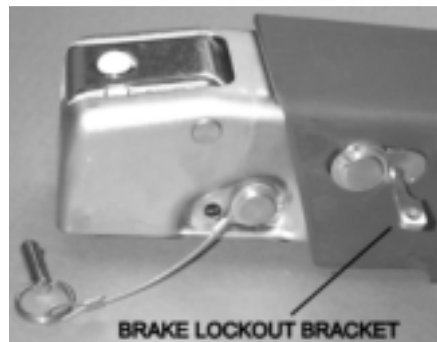

**FIGURE 8**

## BRAKE LOCKOUT CAP

This type of lockout is an available option. It allows trailers to be backed up over soft ground or up inclines without fully engaging the brakes. This lockout is designed to disengage when the trailer is pulled forward after backing up. Therefore it must be manually reset prior to each back up.

### Operating Brake Lockout Cap

1. To operate lockout cap, the actuator must be fully extended. This can be done by pulling the trailer forward slowly.
2. With the lockout cap in the TOW (forward) position, depress the button in the front of the cap and rotate the cap clockwise toward the BACKING position until it stops. The button should remain down.
3. Back the trailer.

4. If the trailer needs to be pulled forward, there are two options:
  - a) Pull the trailer forward and let the coupler move forward. The control cap will rotate (reset) and you will have to turn it back to the BACKING position in order to back up.
  - b) If you have backed up an incline, allow the tow vehicle to move forward slowly so the coupler stays back. This keeps the control in the engaged (BACKING) position so you can back up again.



After the trailer is removed from the tow vehicle after backing up, block the trailer wheels, and move the coupler all the way forward by hand. This will remove the lockout and moved the cap to the TOW

position. BE CAREFUL – if trailer is parked downhill, it may roll forward.

#### Remove Brake Lockout Cap

1. Make sure the coupler is moved all the way forward.
2. With the cap in the TOW position, press the button and rotate the cap counterclockwise toward the REMOVE position until it stops.
3. Lift the cap up to remove it and gain access to the master cylinder reservoir.



Before towing trailer, be sure that the lockout cap is working properly, the cap button is up and cap is in the normal TOW position. If cap does not reset or work properly remove cap from trailer. If you do not

remove a cap that does not work, it may cause the trailer brakes not to work properly.

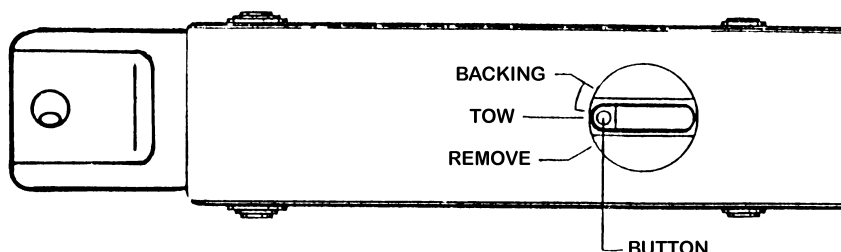

**FIGURE 9 BRAKE LOCKOUT CAP**

#### Automatic Brake Lockout

An automatic brake lockout is recommended if the trailer has disc brakes. Whenever you back up, a 12 volt electrical signal from the tow vehicle backup light circuit energizes the pressure control unit. Hydraulic pressure is prevented from building up so the brakes will not come on.

The electrical control may also be used with drum brakes. To change the existing master cylinder in the actuator will have to be replaced. Call UFP if you want to make this change.

## PARKING AFTER USE



After parking the trailer ALWAYS move the coupler all the way forward by hand to keep moisture from coming in contact and corroding the master cylinder bore. If trailer has been in salt water, rinse off trailer

and flush out the brake drums or rotors with fresh water.

## CAUTION

If you are not skilled in the following procedures, we recommend you contact your dealer for this service. If you have any questions contact our customer service department at (760) 744-1610.

## PERIODIC INSPECTION AND MAINTENANCE

In order to ensure efficient operation, the following checkpoints should be observed annually or every 2000 miles, whichever occurs first.

1. Inspect tow hitch per tow hitch manufacturer's instructions for corrosion or damage. Repair or replace components as necessary.
2. Check for wear on hitch ball. Ball diameter must be in the range of 1.970" - 2.000" (A-60 & A-75) or between 2.282" - 2.312" (A-84) when measured in all directions. If ball is worn, it is UNSAFE and must be replaced. It could cause improper brake performance, separation of ball and actuator, or noisy and jerky trailer operation.
3. Check coupler latch operation for excessive wear and fit on ball. Check fit on ball as outlined in "Coupler" section of the "Safety Checks Before Towing" Section.

## WARNING

A loose fit may allow coupler portion of actuator and ball to separate.

4. Check coupler mechanism for smooth operation. If button is hard to push or latch handle does not spring open after being disengaged, lubricate points on coupler latch mechanism indicated by arrows in Figure 12. (A-60 only)

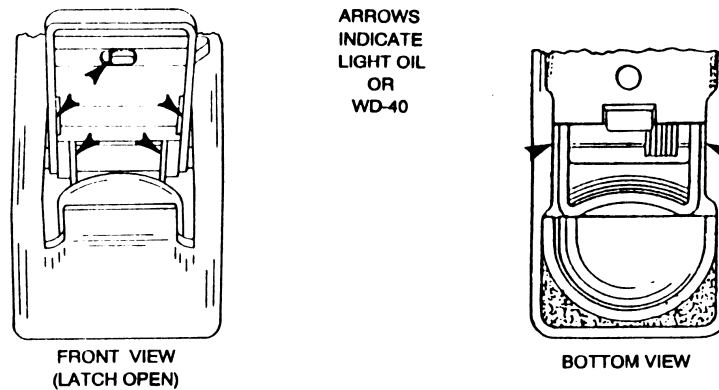

**FIGURE 10 COUPLER LUBRICATION POINTS**

5. Check actuator for excessive wear. If the outer member is rubbing against the inner member, wear marks will show on top coupler just forward of outer member. Contact factory for replacement parts.
6. Check actuator travel. Excessive actuator travel (over one inch) when brakes are applied indicates a need to adjust the brakes (not necessary with disc brakes) or air in the brake lines.

7. Check brake fluid in the master cylinder reservoir. To gain access to the reservoir, remove the cap on top of the actuator. Clean area around master cylinder plug. Use a screwdriver to carefully pry off plug. Make sure rubber seal around opening is in good condition. Clean brake fluid off level indicator on plug. Re-install and remove plug. Brake fluid should just touch the end of the level indicator.
8. Check for foam or bubbles in the brake fluid. If either are present, drain fluid from master cylinder and replace only with new brake fluid of the same type, (DOT 3 or 4). In order for brakes to function properly all air must be expelled from the brake system. If bleeding is necessary, follow "MANUAL BLEEDING OF THE BRAKE SYSTEM" instructions as outlined in this booklet.

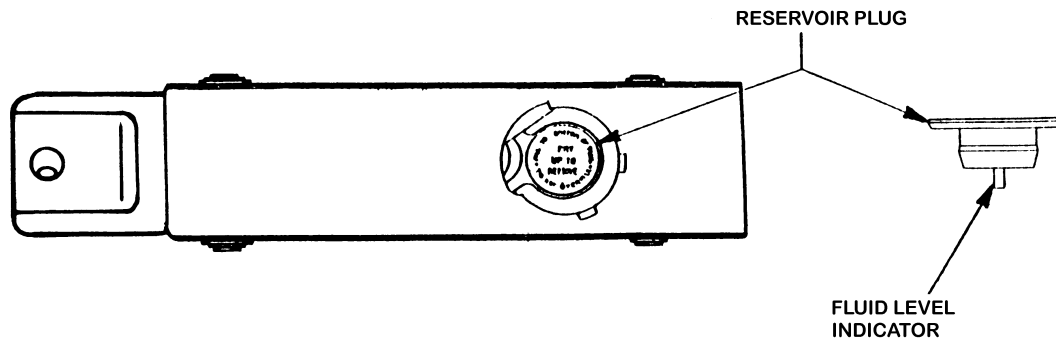

**FIGURE 11 MASTER CYLINDER RESERVOIR PLUG**

**NOTE:** It is imperative that the system be filled with only ONE type of brake fluid. Different types do not mix. DOT 3 and 4 are used by most manufacturers. Follow instructions on brake fluid container.

9. Check safety chains and attachment points for damage or wear. Repair or replace as necessary.
10. Check the breakaway cable for worn or frayed cable strands. End fittings should be checked for damage. Replace if necessary.
11. Check for any hydraulic leaks in the brake system. Be sure all tube fittings are tight. Periodic checks must be made on all hoses, brake line tubing and fittings to guard against cuts, worn hoses and loose fittings which may cause leaks in trailer brake hydraulic system. Replace deteriorated and damaged parts as necessary.
12. Check brake adjustment (not necessary for disc brakes) after first 300 miles and every 2000 miles thereafter. **PROPER ADJUSTMENT OF BRAKES IS EXTREMELY IMPORTANT FOR STOPPING CAPABILITY.** If brakes are in need of adjustment, we recommend that you follow the manufacturer's instructions or steps outlined in this booklet.

# EXTENDED STORAGE MAINTENANCE

(Over one year)

The following preventive maintenance is recommended for extended periods of storage.

1. Check brake system for fluid level in master cylinder. If fluid level is extremely low, air may be trapped in brake lines. Bleed all lines if necessary and fill reservoir to proper level.
2. Lubricate all links and pivots to prevent rusting.

If equipped with drum brakes and storage is in a humid environment, remove wheel and drum assemblies and spray a good anti-corrosion compound (CRC Formula 5-56, for example) under rubber boot on forward end of brake wheel cylinder. Also, spray springs, adjuster and anchor pin.



Avoid spraying drum and brake lining surfaces.

3. Grease bearings, fill hub cavities and reinstall wheel and drum assemblies.
4. Top off bearing protectors, if equipped, with grease.
5. Make sure breakaway system has not been set, and actuator is fully extended.
6. If possible, store away from excessive moisture.

# BRAKE ADJUSTMENT

Raise one trailer wheel at a time, remove the dust cover from the adjusting slot at the lower part of the back side of the brake assembly. Insert brake adjusting tool or screwdriver as shown. Adjust brake shoes out until wheels will not rotate in the forward direction by moving the end of the adjusting tool toward top of brake as illustrated. When this condition is felt, back off (loosen) the adjustment as follows:

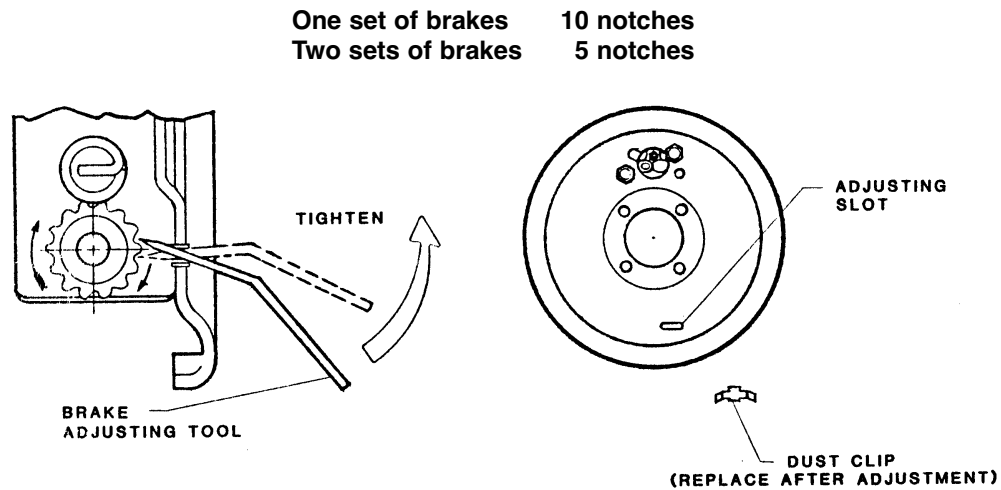

FIGURE 12 ADJUSTING BRAKES

**Note:** UFP 10" brake drums have a hole on the front side to permit brake lining inspection and access to the brake shoe adjustment star wheel. Simply remove the trailer wheel to access the inspection hole.

We recommend that your trailer brakes be adjusted after the first 300 miles of use and at least every 2,000 miles thereafter. In addition, the trailer brakes should also be inspected after the first two years of service for wear and corrosion (one year after substantial salt-water immersion). Service, lubricate and/or replace parts as necessary for safe, sure operation. Thereafter, set up a maintenance schedule that assures proper inspection and adjustment of brakes. The time interval should be based on towing conditions, operating environment (salt vs. fresh water, etc.) distance towed, storage conditions, etc. The goal is simple. Make sure your brakes will work properly when you need them most, in an emergency stop. Plated and galvanized brakes are now available and are better able to withstand corrosion.

## HYDRAULIC DISC BRAKE ADJUSTMENT

Hydraulic disc brake adjustment is not necessary, they are self-adjusting.

# TROUBLESHOOTING BRAKE PROBLEMS



If any of the following problems develop, the trailer must be immediately stopped and the proper corrective action taken before the trailer is put back into service. Failure to do so may lead to loss of proper trailer braking capability, or damage to the trailer and load.

<b>PROBLEM: COUPLER LATCH HANDLE DOES NOT OPEN OR CLOSE EASILY</b>	
<b>POSSIBLE CAUSE</b>	<b>REMEDY</b>
Oversize hitch ball	A-60 & A-75, check ball size at several positions, ball should be within 1.970"-2.000" in diameter. A-84, check ball size at several positions, ball should be within 2.282"-2.312" in diameter. Replace if necessary.
Ball not fully inserted in ball socket.	Check for proper ball size, (see above) and positive tongue load. Check to see if tongue jack is fully retracted. Make sure there are no foreign objects or excessive paint inside coupler cavity.
Trailer and tow vehicle are not level with each other, or are facing downhill.	Reposition tow vehicle and trailer or block trailer tire and extend actuator.
Excessive corrosion	Lubricate or replace parts as necessary.



If the latch handle does not close freely, DO NOT tow the trailer until cause of the problem is located and eliminated. Forcing latch handle closed will make opening latch handle extremely difficult.

<b>PROBLEM: SQUEAKING, CLUNKING AND CLATTERING AT ACTUATOR</b>	
<b>POSSIBLE CAUSE</b>	<b>REMEDY</b>
<p>Hitch ball requires lubrication.</p> <p>Loose hitch ball</p> <p>Loose hitch</p> <p>Loose mounting bolts (if equipped)</p> <p>A worn or too small hitch ball.</p> <p>Worn shock absorber</p> <p>Air in brake lines allowing actuator to travel too far.</p> <p>Trailer is equipped with “free backing brakes”.</p>	<p>Lubricate with conventional multipurpose lubricant or commercial lubricant made for hitch balls.</p> <p>Inspect hitch ball and tighten.</p> <p>Inspect hitch and repair.</p> <p>Inspect brake actuator mounting bolts and tighten as necessary, (70-80 ft-lbs).</p> <p>Replace hitch ball with a quality unit that meets SAE specifications.</p> <p>Replace shock absorber.</p> <p>Check for leaks, re-bleed brakes.</p> <p>Clunking noise is typical for these types of brakes as long as braking performance is normal.</p>
<b>PROBLEM: WHEN BRAKING, BRAKES REPEATEDLY COME ON AND RELEASE, BREAKING IS NOT SMOOTH, THIS CONDITION IS CALLED “CHUCKING”</b>	
<p>Worn out shock absorber in actuator.</p> <p>Loose hitch or hitch ball.</p> <p>Not enough tongue weight or shocks on tow vehicle too soft.</p> <p>Air in the brake lines.</p> <p>Brakes out of adjustment.</p> <p>Contaminated brake linings.</p> <p>Rusted master cylinder bore.</p> <p>Breakaway cable has been pulled.</p>	<p>Replace the shock absorber.</p> <p>Correct as necessary.</p> <p>Correct as necessary.</p> <p>Bleed the brake system.</p> <p>Adjust the brakes properly.</p> <p>Fix cause of contamination (leaky wheel cylinder or hub grease seal). Replace linings and clean braking surface on drum or rotor.</p> <p>Replace actuator master cylinder.</p> <p>Reset push rod release bracket.</p>



<b>PROBLEM: BRAKES DO NOT OPERATE, POOR BRAKE PERFORMANCE</b>	
<b>POSSIBLE CAUSE</b>	<b>REMEDY</b>
<p>Worn out brake shoes or disc brake pads.</p> <p>Foreign material in the brake unit assembly.</p> <p>Insufficient amount of hydraulic fluid.</p> <p>Broken lines or pinched line.</p> <p>Seized actuator master cylinder. Prevents piston from stroking.</p> <p>Corrosion/rust keeps brake from operating.</p> <p>Inadequate brakes for load or driving conditions.</p>	<p>Replace brake shoes/pads on both sides of axles and check drums/rotors for wear or damage.</p> <p>Clean thoroughly. Replace shoes and linings if contaminated.</p> <p>Fill reservoir and bleed brakes. Check for leaks.</p> <p>Replace faulty lines and bleed brakes.</p> <p>Replace actuator master cylinder.</p> <p>Replace damaged components or entire brake assembly as required.</p> <p>If you have a tandem axle trailer add a second set of brakes.</p>
<b>DRUM BRAKES ONLY</b>	
<p>Incorrect adjustment of drum brake.</p> <p>Broken components in brake assembly.</p> <p>Leaky or seized brake wheel cylinder.</p>	<p>Adjust all brakes.</p> <p>Replace faulty parts and re-adjust brakes.</p> <p>Replace/rebuild wheel cylinder and replace brake shoes (if contaminated with brake fluid). Clean drums and other hardware, readjust brakes and bleed brake system.</p>

<b>PROBLEM: ONE BRAKE OVERHEATING</b>	
<b>POSSIBLE CAUSE</b>	<b>REMEDY</b>
<p>Drum brake adjusted too tightly.</p> <p>Disc brake caliper does not permit brake pads to release.</p> <p>Leaky or seized brake wheel cylinder.</p> <p>Damaged or frozen brake mechanism.</p>	<p>Readjust, check all brakes.</p> <p>Check Caliper. Sections must be free to move apart. If frozen, remove and free up. Caliper piston may freeze up and prevent pads from retracting. Clean contaminants out of piston cavity. Replace piston, seal and protective dust cover boot. Bleed system.</p> <p>Replace/rebuild wheel cylinder and replace brake shoes (if contaminated with brake fluid). Clean drums and other hardware, readjust brakes and bleed brake system.</p> <p>Rebuild or replace brake unit.</p>
<b>PROBLEM: BOTH BRAKES OVERHEATING</b>	
<p>Isolate the problem to actuator or the brakes as follows:</p> <ol style="list-style-type: none"> <li>1. Fully extend actuator.</li> <li>2. Remove master cylinder reservoir plug.</li> <li>3. Check that reservoir is properly filled.</li> <li>4. Manually push the actuator inner member in or use a screwdriver to stroke pushrod. (Be sure to depress the pushrod release button after stroking pushrod).</li> <li>5. In the first 1/8" of stroke, the reservoir fluid will either remain dead calm or swirl around.</li> </ol> <p>If the fluid swirls:  Fluid is allowed to return to reservoir when actuator is extended.  Actuator is functioning properly, troubleshoot brakes.</p>	
<b>POSSIBLE CAUSE</b>	<b>REMEDY</b>
<p>Drum brakes misadjusted.</p> <p>Trailer stored with actuator compressed; rust has caused both brakes to freeze up.</p> <p>Inadequate brakes for towed load or driving conditions.</p> <p>Pinched or kinks in brake lines.</p>	<p>Adjust brakes properly.</p> <p>Remove brakes. Clean, repair or replace components as necessary.</p> <p>If you have a tandem axle trailer add a second set of brakes.</p> <p>Check brake lines and replace as necessary.</p>

<p>If fluid does NOT move:          Brake system is remaining pressurized and there is an actuator problem.          Troubleshoot actuator.</p>	
POSSIBLE CAUSE	REMEDY
<p>Pulled breakaway cable, pushrod not reset</p>	<p>Reset breakaway cable, install clip.</p>
<p>For each of the following the actuator inner member must be removed. Follow the instruction in "HOW TO TAKE APART AND ASSEMBLE THE ACTUATOR".</p>	
<p>Fluid return hole in master cylinder clogged or mispositioned.</p> <p>Corrosion in master cylinder freezing up piston or not allowing it to fully retract, usually caused by railer stored with actuator compressed.</p> <p>Other malfunction or damage keeping the master cylinder piston from retracting.</p>	<p>Troubleshoot.          Replace parts as necessary.</p>

# HOW TO TAKE APART AND ASSEMBLE THE ACTUATOR

## DISMANTLING ACTUATOR

**Note:** Read and understand this section before attempting to disassemble inner member.

1. Extend actuator and remove cap from top.
2. Unscrew brake line fitting from rear of master cylinder. **Note:** Brake fluid escaping from master cylinder and brake line will damage paint. Care should be taken to protect painted surfaces.
3. Remove one retaining ring and washer from each of the two roller pins located on side of actuator main body and slide pins out.
4. Pull on brakeaway cable to remove inner member. This ensures that all components will come out attached together. Internal components can now be removed and dismantled for inspection, maintenance or repair. Entire inner member can be replaced.

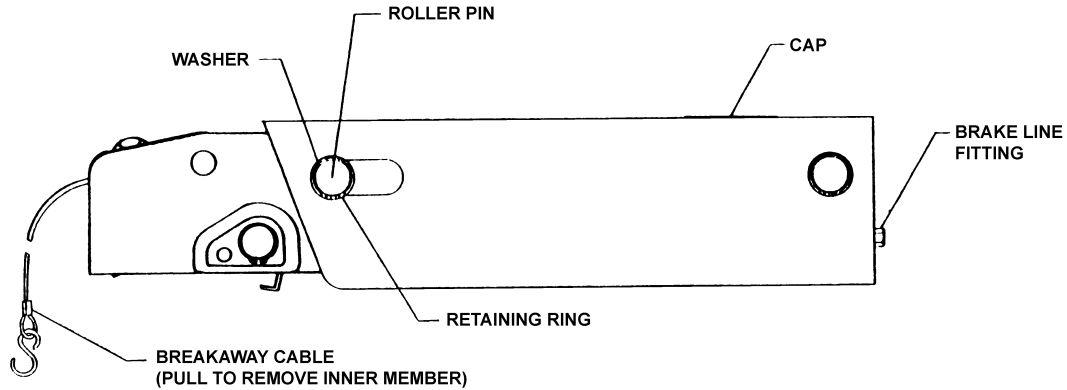
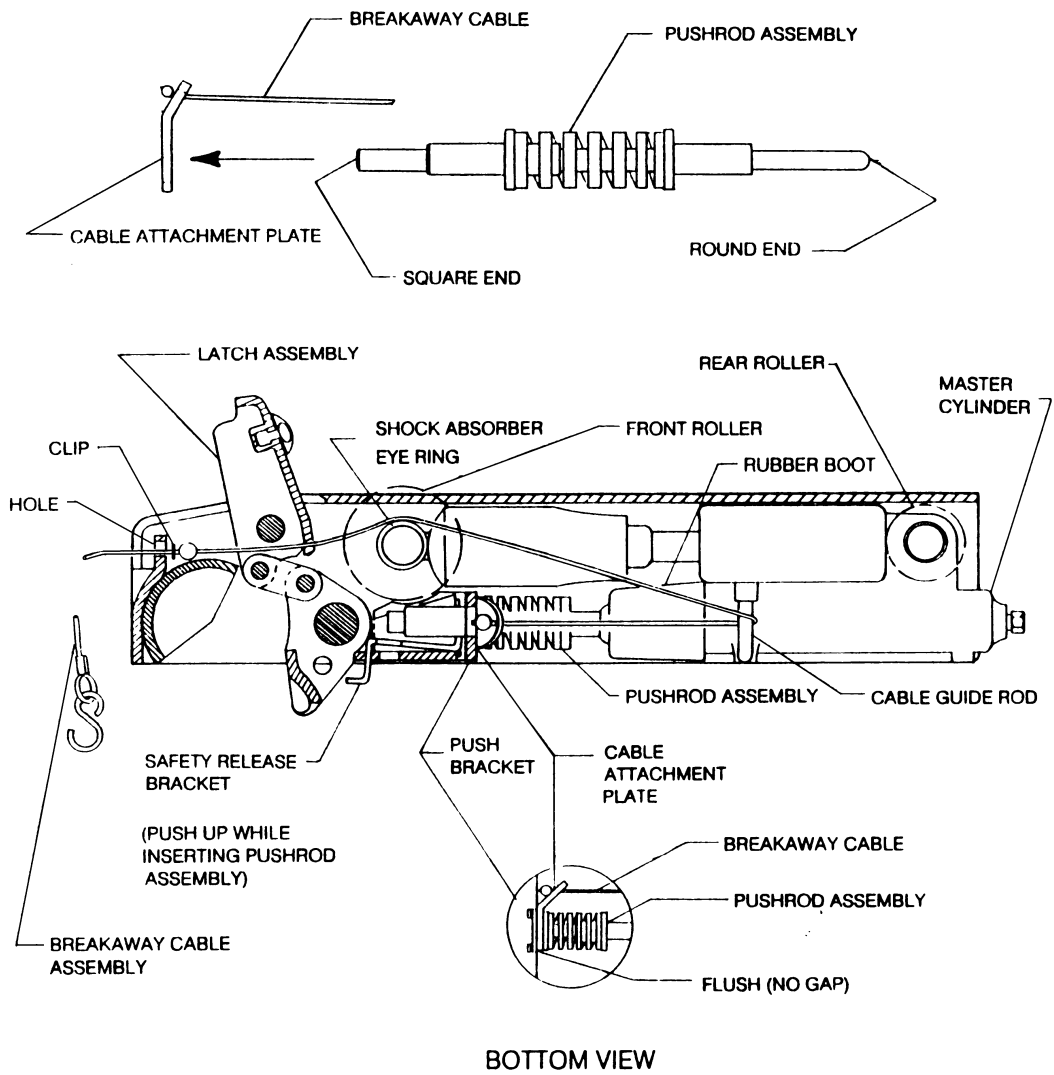

FIGURE 14 A-60 ACTUATOR, SIDE VIEW (A-75 & A-84 similar)

## **ACTUATOR ASSEMBLY**

Before the inner member can be inserted into the main body all internal components must be assembled and placed in their proper position.

1. For ease of assembly, assemble inner member upside down.
2. Check that shock absorber, reservoir cover plate, diaphragm, and plug are assembled to the master cylinder.
3. Insert ball end of breakaway cable through hole in front of inner member, thread through latch assembly and around out side of cable guide rod located on the side of master cylinder. Ball end of cable can now be inserted into hole on cable attachment plate and slid over into slot. Note orientation of cable attachment plate.
4. Insert square end of push rod assembly into hole in cable attachment plate. Insert round end of push rod assembly through rubber boot and into master cylinder piston.
5. Lightly grease rear rollers and hold them in the pockets in the sides of the master cylinder while inserting entire assembly into the inner member from the back end. While inserting assembly make sure push rod enters hole in push rod bracket. The tab on the safety release bracket will have to be depressed to allow push rod assembly to fully enter hole in push bracket. The cable attachment plate should sit flush with the push bracket if properly assembled.
6. Make sure breakaway cable is correctly routed and is not wrapped around or hung up on any components.
7. While supporting the master cylinder, turn inner member assembly over and lightly grease front rollers and insert them through the openings on top of inner member. Note: Before inserting rollers make sure breakaway cable runs on top of shock absorber eye ring. Install top pad on top of the actuator in the roller slots.
8. Slide actuator inner member into outer member and line up roller pin holes on rear of actuator first. Insert lightly greased roller pin.
9. Push or pull inner member to line up holes in rollers with hole in shock absorber eye-ring and insert lightly greased roller pin.
10. Pull on inner member to the fully extended position. With slack taken out of breakaway cable, check that the cable clip is in place next to the indicator bead. Push up on safety release bracket tab to reset breakaway system.
11. Assemble washers and retaining rings on roller pins.
12. Connect brake line fittings and install cap.
13. Bleed brake system according to instructions outlined in "MANUAL BLEEDING OF THE BRAKE SYSTEM" section.



NOTE: ORIENTATION OF CABLE ATTACHMENT PLATE IS TOWARD SIDE OF INNER MEMBER.

**FIGURE 13 COMPONENT LOCATION (A-60 Inner Member)**

# MANUAL BLEEDING OF THE BRAKE SYSTEM



## CAUTION

If you are not skilled in performing the following procedures, have a qualified service shop perform the job.

Check that all hydraulic fittings are secure. Read and understand all instructions before starting. Two people are required for manual bleeding.

1. Remove the master cylinder reservoir plug and fill the reservoir with brake fluid. Use either DOT 3 or DOT 4 automotive brake fluid. Follow instructions on brake fluid container. Avoid shaking brake fluid container and pour fluid slowly to minimize air entrapment. Let fluid in reservoir stand until completely free of air bubbles.
2. **IMPORTANT:** Before bleeding brake lines, bleed the actuator master cylinder. Insert a screw driver through hole in bottom of inner member and use short strokes to pry on pushrod (while holding safety release bracket up) until no air bubbles are seen coming from small orifice hole in the bottom of the master cylinder reservoir.
3. Start bleeding procedure on the brake furthest from master cylinder.
4. At the brake assembly, connect a transparent bleeder hose to bleed screw fitting on wheel cylinder and submerge free end into a container partially filled with brake fluid. Do not reuse this fluid.
5. The first person strokes the pushrod slowly while holding safety release bracket up. The second person opens the bleed screw fitting. He then closes the bleed screw fitting **BEFORE** the first person **SLOWLY** releases the pushrod. Repeat this procedure until the fluid expelled from the bleeder hose is free of air bubbles. Remember to always tighten the bleeder screw before releasing pushrod. During this procedure, the master cylinder reservoir fluid level must be maintained at no less than 1/2 full.
6. Repeat steps 4 and 5 for the other brake and the brakes on the front axle, if equipped with tandem brake axles.
7. If installation is tandem axle with brakes on both axles, repeat bleeding procedure on rear axle brakes for the second time to assure purging of all air in system.
8. As a final check after bleeding is completed, stroke pushrod and check to be sure brake system is pressurized by attempting to rotate a tire.
9. Push up on the safety release bracket to ensure that pushrod is in released position.
10. After bleeding has been completed, re-check fluid level in master cylinder. Fill the master cylinder reservoir to indicator on reservoir plug. Do not overfill.



RESULT IN BRAKE FAILURE OR COSTLY REPAIRS.

**IMPORTANT: DO NOT USE BRAKE FLUID DRAINED FROM BRAKE SYSTEM TO REFILL MASTER CYLINDER RESERVOIR AS SUCH FLUIDS CONTAIN CONTAMINANTS FROM SYSTEM WHICH MAY**

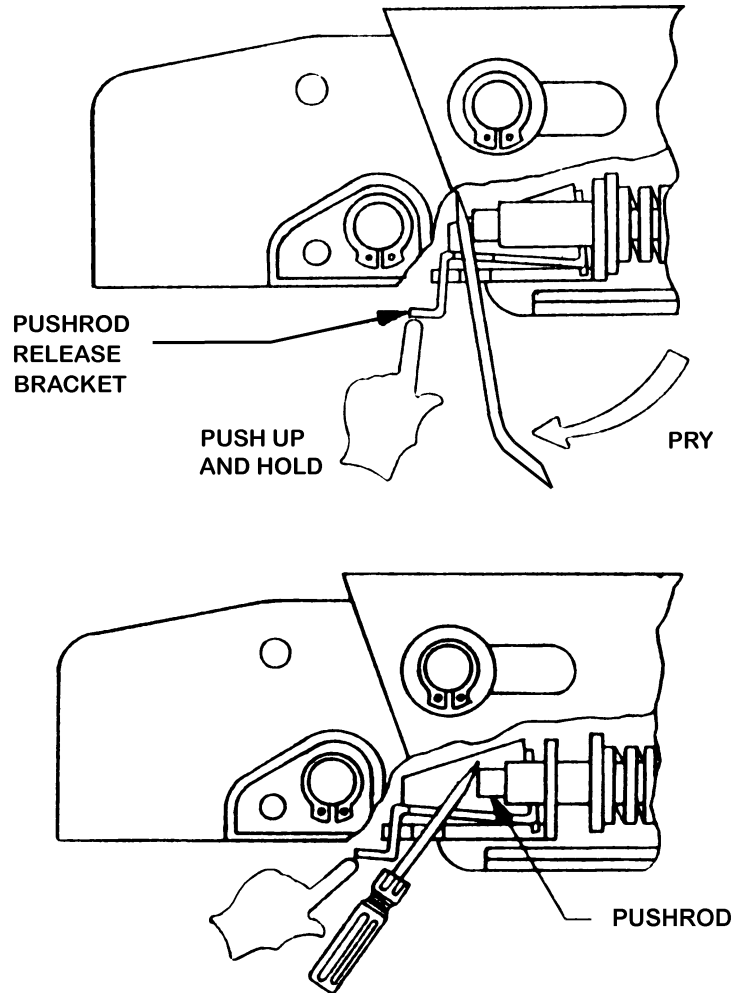

**FIGURE 16 STROKING PUSHROD TO BLEED BRAKES**



## HOW TO INSTALL THE BREAKAWAY CABLE CLIP

The breakaway cable clip is installed on the breakaway cable to prevent inadvertent pressurization of trailer breaks if cable is lightly pulled accidentally. Should the breakaway cable be pulled, during emergency situations, the clip will be destroyed. The breakaway system must be reset by pushing up on the tab located under coupler and the clip must be replaced.

### A-60

To install clip, open latch handle and pull enough cable out of coupler body to make installation of clip easier. Clip must be installed on cable in front of indicator bead as shown below.

### A-75

Install clip from bottom side of coupler by locating cable and installing clip in front of indicator bead.

### A-84

No clip required

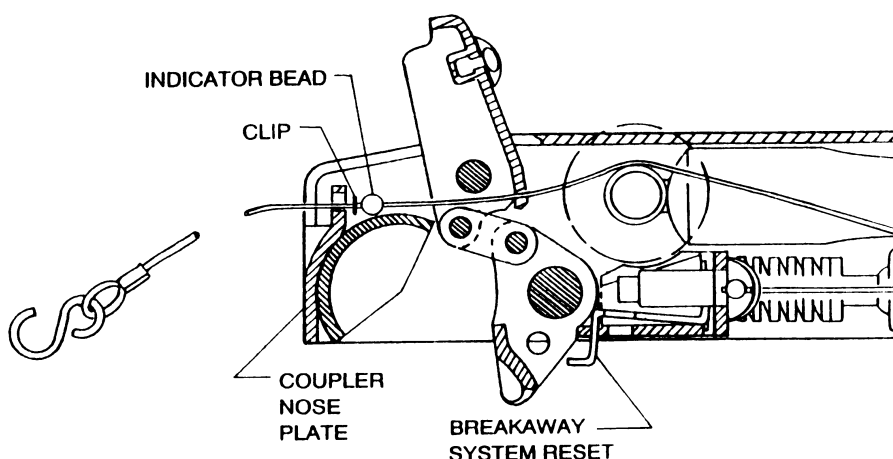

Hold Clip with pliers and insert over cable. Use a second set of pliers to gently close the opened end of clip. Clip should be free to move on cable

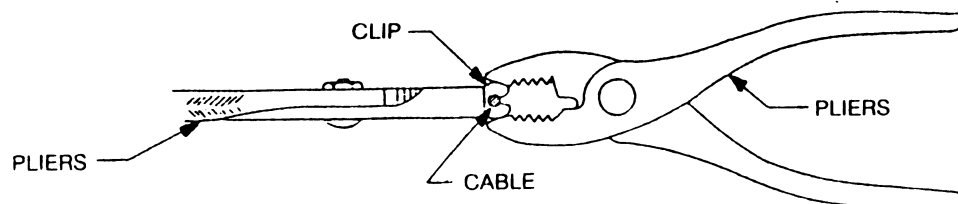

 **CAUTION**

The breakaway system reset tab must be pushed up after clip installation and anytime the cable has been pulled.

# **ACTUATOR DEFINITIONS**

**ACTUATOR** - The device on the front of the trailer, which operates the trailer's brakes in proportion to the tow vehicle stopping.

**GROSS VEHICLE WEIGHT RATING (GVWR)** - This rating is found on the trailer's identification plate. The rating includes the total weight of the trailer and all cargo that it is carrying.

**A-60 ACTUATOR** - An actuator manufactured by UFP with a maximum trailer GVWR of 6,000 lbs and maximum tongue load of 750 lbs.

**A-75 ACTUATOR** - An actuator manufactured by UFP with a maximum trailer GVWR of 7,500 lbs and maximum tongue load of 750 lbs.

**A-84 ACTUATOR** - An actuator manufactured by UFP with a maximum trailer GVWR of 8,400 lbs and maximum tongue load of 840 lbs.

**COUPLER** - The portion of the actuator that receives and secures the tow vehicle hitch ball during towing.

**MASTER CYLINDER** - A hydraulic device in the actuator that supplies brake fluid under pressure to the trailer's brakes in proportion to an input force.

**VEHICLE COMBINATION** - The combination of the tow vehicle and the trailer.

**HITCH** - An apparatus attached under the rear of the tow vehicle that transfers the trailer's tongue and towing loads to the tow vehicle.

**HITCH BALL** - A round ball on a shank attached to the hitch of the tow vehicle used to connect the trailer to the tow vehicle.

**SAFETY CHAINS** - An assembly, which provides a secondary means of connection between the rear of the towing vehicle and the front of the trailer.

**WEIGHT DISTRIBUTING HITCH** - A device that transmits the tongue load of the trailer from the rear wheels of the tow vehicle to the front wheels of the tow vehicle.

**SOCIETY OF AUTOMOTIVE ENGINEERS (SAE) J684 STANDARD** - This SAE Standard includes couplings, hitches, and safety chains used in conjunction with all types of trailers or towed vehicles whose Gross Vehicle Weight Rating (GVWR) does not exceed 10,000 lbs.

**TRAILER SWAY CONTROL DEVICES** - After market devices intended to eliminate or control the amount of trailer sway (side to side movement) during towing.

**PUSHROD RELEASE BRACKET** - A part of the actuator that holds the master cylinder pushrod in the engaged position supplying constant pressure to the trailer brakes when the safety cable has been pulled.

**TONGUE WEIGHT** - A portion of the total trailer weight that is supported by the coupler.

**LOAD RATING** - The maximum load that a component or device can safely carry or support without failure.

**BRAKE LOCKOUT CAP** - An optional device that is located on top of the UFP actuator that allows the trailer to be backed up over soft ground or up an incline without fully engaging the trailer brakes.

**BRAKE LOCKOUT BRACKET** - A device that is inserted into the side of the UFP actuator that allows the trailer to be backed up over soft ground or up an incline without fully engaging the trailer brakes.

# PARTS LIST

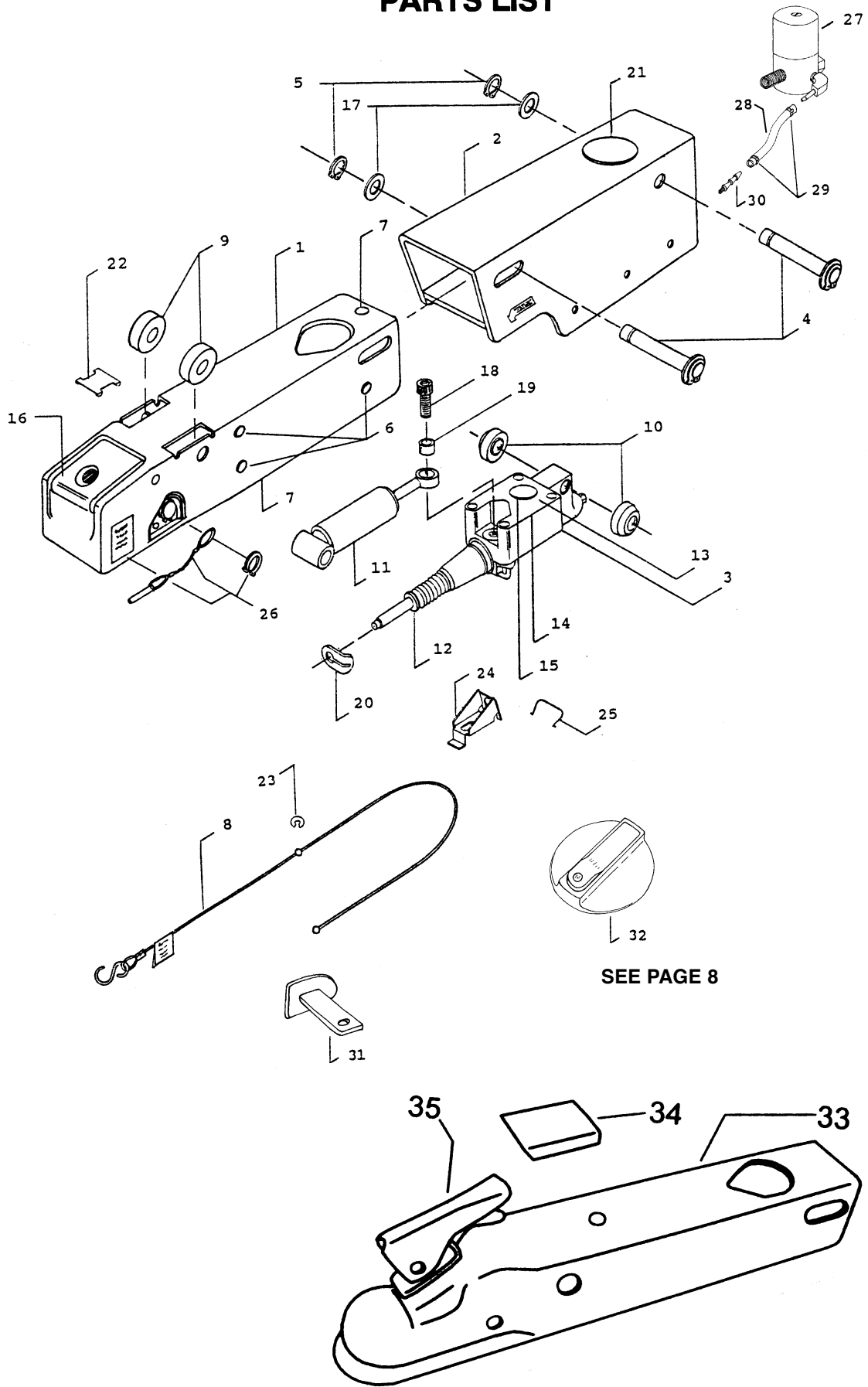

ITEM NO.	PART NO.	DESCRIPTION	QUANTITY
1	34021	A-60 Inner Member, Primary Assy.	1
2	various	Outer Member	1
3	35154	Master Cylinder Assembly	1
	34762	Master Cylinder for use w/Solenoid	1
4	34079	Roller Pin	2
5	32262	Retaining Ring	2*
6	32260	Wear Pad, Thin (sides)	6
7	32263	Wear Pad, Thick (top/bottom)	3
8	34370	Breakaway Cable Assembly	1
9	34371	Front Roller (A-60 only)	2
10	32310	Rear Roller	2
11	32306	Shock Absorber	1
12	35112	Pushrod Assembly	1
13	34300	Reservoir Plate Cover	1
14	32288	Reservoir Diaphragm	1
15	32286	Reservoir Plug	1
16	36360	A-60 Latch Replacement Kit	1
17	32554	Roller Pin Washer	2*
18	32291	3/8-16 x 1.00" Bolt	1
19	34301	Shock Absorber Bushing	1
20	34380	Cable Attachment Plate	1
21	32547	Outer Member Cap, Plastic	1
22	32592	A-60 Top Pad	1
23	34355	Breakaway Cable Clip	1
24	34378	Pushrod Release Bracket	1
25	32546	Pushrod Release Bracket Spring	1
26	34545	Hitch Pin Kit (Pin, Decal & Retainer)	1
27	34500	Solenoid Valve with Fittings	1**
28	34508	Reverse Valve Drain Tube	1**
29	32269	Nylon Cable Tie	2**
30	32570	#10-32 Mini-Barb Fitting	1**
31	34557	Side Lockout Kit	
32	34359	Top Lockout Upgrade	
33	47720	A-75 Inner Member, Primary Assy.	1
34	47710	A-75 Top Pad	1
35	36368	A-75 Latch Replacement Kit	1
36	34566	A-75 Hitch Pin Kit	1
Not Shown	40100	A-84 Inner Member, Primary Assy.	1
	47710	A-84 Top Pad	2
	40120	A-84 Latch Replacement Kit	1
	40110	A-84 Hitch Pin Kit	1
	* Per Pin	** Not applicable to all models	

## **FIVE YEAR LIMITED WARRANTY A-60, A-75 & A-84 BRAKE ACTUATOR**

The actuator is guaranteed against defects in materials and workmanship under normal use and service for a period of five years after the date of trailer purchase by the first owner.

### **Limitations of Coverage**

This warranty does not cover:

Normal wear and tear, including corrosion.

Damage caused by accidents, overload, abuse, modification or improper use of product.

This warranty is limited to defective parts replacement only. Charges for installing replacement parts, damage incurred to other equipment as well as incidental or consequential damages connected therewith are excluded. Some states do not allow the exclusion or limitation of incidental or consequential damages, so the above limitations may not apply to you.

### **Repair or Replacement Procedure**

If a failure or defect occurs during the warranty period, promptly contact warrantor's (UFP) customer service department. Until such notice is received, warrantor will not be responsible for any repair or replacement costs. UFP, at its option, may require return of the component in question to the factory, transportation charges prepaid. UFP will replace, FREE OF CHARGE, either the entire actuator assembly or the part that proves defective, at its option. Any part found not to be defective will be returned freight collect with an explanation. Installation of parts and adjustment of brake systems MUST be performed by a skilled brake mechanic and service manual instructions must be followed.

### **Vehicle identification Number (VIN)**

The VIN is a 17 digit number located on the trailer identification label. The label is located on the left side of the trailer. Be sure to include the VIN number in all communications with Warrantor.

### **Purchaser's Rights**

This warranty gives you specific legal rights, and you may also have other rights which vary from state to state.

### **Product improvement**

UFP has a policy of continuous product improvement. We reserve the right to change or improve the design of our products without assuming an obligation to modify any product previously manufactured.



*San Marcos, CA ★ Winchester, TN*

135 Sunshine Lane ★ San Marcos, CA 92069  
(760) 744-1610 ★ Fax (760) 744-1616 ★ [www.ufpnet.com](http://www.ufpnet.com)

Service Information  
for

**TRAILER**  
**Buddy**<sup>®</sup>  
**DISC BRAKES**  
MODEL DB35



**TRAILER**  
**Buddy**<sup>®</sup>  
**PRODUCTS BY LFP**  
San Marcos, CA • Winchester, TN

# **TRAILERING WITH DISC BRAKES**

Disc brakes offer several advantages over drum brakes that you will appreciate. Disc brakes have improved resistance to fade on downhill grades. They are self adjusting, so as pads wear, braking efficiency is not reduced. They recover quickly after being submerged. They require less maintenance, are easier to flush out, and are less susceptible to water induced corrosion.

Your trailer's brakes are designed to energize automatically when the tow vehicle's brakes are applied. These are known as "surge brakes". When the vehicle slows down or stops, the forward momentum (surge) of the trailer against the hitch ball develops hydraulic pressure in a master cylinder inside the trailer brake actuator. Hydraulic lines are used to transfer pressure to the brakes and engage them.

Follow the tow vehicle manufacturer's guidelines with respect to towing capability, hitch requirements, and other towing considerations.

## **OPERATING TIPS**

### **Check Your Brake System Before Each Trip**

1. Follow the pre-towing instructions that came with your actuator.
2. Make sure there are no leaks in the hydraulic system.
3. A surface rust will build up on the rotor brake surface if the trailer isn't used for a week or more. The brake pads will wipe off the rust in the first few miles of travel. If the trailer has been idle for several months, or has been frequently submerged in salt water and the brakes not flushed out, severe corrosion can occur. Review the maintenance instructions in the following section.

### **When Starting Out**

1. The trailer should tow easily. If it seems hard to pull or wants to swing toward one side, a rotor may not be rotating freely. Investigate and solve the problem.
2. Try your brakes at slow to moderate speeds and develop the "feel" to sense they are functioning properly.

# **TRAILERING WITH DISC BRAKES**

Disc brakes offer several advantages over drum brakes that you will appreciate. Disc brakes have improved resistance to fade on downhill grades. They are self adjusting, so as pads wear, braking efficiency is not reduced. They recover quickly after being submerged. They require less maintenance, are easier to flush out, and are less susceptible to water induced corrosion.

Your trailer's brakes are designed to energize automatically when the tow vehicle's brakes are applied. These are known as "surge brakes". When the vehicle slows down or stops, the forward momentum (surge) of the trailer against the hitch ball develops hydraulic pressure in a master cylinder inside the trailer brake actuator. Hydraulic lines are used to transfer pressure to the brakes and engage them.

Follow the tow vehicle manufacturer's guidelines with respect to towing capability, hitch requirements, and other towing considerations.

## **OPERATING TIPS**

### **Check Your Brake System Before Each Trip**

1. Follow the pre-towing instructions that came with your actuator.
2. Make sure there are no leaks in the hydraulic system.
3. A surface rust will build up on the rotor brake surface if the trailer isn't used for a week or more. The brake pads will wipe off the rust in the first few miles of travel. If the trailer has been idle for several months, or has been frequently submerged in salt water and the brakes not flushed out, severe corrosion can occur. Review the maintenance instructions in the following section.

### **When Starting Out**

1. The trailer should tow easily. If it seems hard to pull or wants to swing toward one side, a rotor may not be rotating freely. Investigate and solve the problem.
2. Try your brakes at slow to moderate speeds and develop the "feel" to sense they are functioning properly.



## **Upon Return Home**

If you have been into saltwater, flush rotors and calipers thoroughly with fresh water to minimize subsequent corrosion.

## **Back-up Feature**

We offer an electrically operated valve that is mounted on the actuator and is connected to the tow vehicle back-up lights. Whenever they are energized, the valve opens and prevents pressure buildup in the system. Otherwise, you could not back up. Most trailer manufacturer's use this valve.

If you try to back up and can't, check the valve. When it is energized (by shifting into reverse) you can hear a noticeable "click" sound. If you don't, check for an electrical problem.

## **Storage**

Whenever you park the trailer, make sure the actuator is fully extended. This position relieves pressure on the brakes. Actuators sometimes freeze up in the compressed position from corrosion. The next time out, the brakes will drag and overheat.

# **ROUTINE MAINTENANCE**

## **Hose Them Off**

If you have been in saltwater, the single most important maintenance step for disc (or drum) brakes is to flush them thoroughly with fresh water.

## **Watch For Corrosion**

Light surface rust on rotors is common and not a problem as discussed elsewhere.

Extremely thick, heavy rust on rotor surfaces will not allow the wheel assembly to rotate freely, resulting in heat build-up and premature wear on components. Clean or replace components as necessary.

We recommend you check for rust damage at least annually. More frequently if used in very humid environments, or in saltwater.

## Pad Wear

Pads must be replaced when 3/32' (.094') or less of the pad friction material is left.

 **WARNING:** If you are not familiar with disc brake pad replacement, have this work performed by a qualified service shop. Improper pad replacement may decrease braking effectiveness, potentially causing an accident from not being able to stop the tow vehicle combination within an acceptable distance.

## Rotor Damage

Rotors should be resurfaced by a qualified brake specialist if extreme galling or wear marks are present.

 **WARNING:** Rotors must be replaced if the distance between brake surfaces becomes less than 0.670" (17.0mm) due to wear or machining. Otherwise, brake effectiveness and rotor integrity will be reduced resulting in loss of brakes.

Check pad and rotor condition at least annually.

## Actuator and Hydraulic Line Service

Follow actuator manufacturer's suggested service routine. Always be sure hydraulic fluid is clean. Be sure that fluid level is within 1/2 inch of top of reservoir. **Do not** fill beyond that level. Brake systems use DOT 3 hydraulic fluid. Check for leaks in the brake lines and fittings. Leaks will lead to loss of trailer braking ability. Repair or replace as necessary.

## Replacement Parts

All replacement parts can be purchased from the trailer manufacturer or UNIQUE FUNCTIONAL PRODUCTS. Replacement pads, pistons and dust boots can also be purchased from auto part stores:

<u>YEAR</u>	<u>MODEL</u>
1997-2000	Kia Sephia

**NOTE:** Use only organic, non-metallic pads. Metallic pads will rust and depreciate rotor surface.



## TWO YEAR LIMITED WARRANTY

These disc brakes are guaranteed against defects in materials and workmanship under normal use and service for a period of two years after the date of trailer purchase by the first owner.

### Limitations of Coverage

This warranty does not cover:

Normal wear and tear, including corrosion

Damage caused by accidents, overload, abuse, modification or improper use of product.

This warranty is limited to defective parts replacement only. Charges for installing replacement parts, damage incurred to other equipment as well as incidental or consequential damages connected therewith are excluded.

Some states do not allow the exclusion or limitation of incidental or consequential damages, so the above limitations may not apply to you.

### Repair or Replacement Procedure

If a failure or defect occurs during the warranty period, promptly contact warrantor's (UFP) customer service department. Until such notice is received, warrantor will not be responsible for any repair or replacement costs. UFP, at its option, may require return of the component in question to the factory, transportation charges prepaid. UFP will replace; FREE OF CHARGE, either the entire disc brake assembly or the part that proves defective, at its option. Any part found not to be defective will be returned freight collect with an explanation. Installation of parts and adjustment of brake systems MUST be performed by a skilled brake mechanic and service manual instructions must be followed.

### Use of Vehicle Identification Number (VIN)

The VIN is a 17-digit number located on the trailer identification label. The label is located on the left side of the trailer. Be sure to include the VIN number in all communications with Warrantor.

### Purchaser's Rights

This warranty gives you specific legal rights, and you may also have other rights, which vary, from state to state.

### Product Improvement

UFP has a policy of continuous product improvement. We reserve the right to change or improve the design of our products without assuming an obligation to modify any product previously manufactured.

33133



135 Sunshine Lane • San Marcos, CA 92069  
760-744-1610 • Fax 760-744-1616 • [www.ufpnet.com](http://www.ufpnet.com)



# QUICK-LOCK TRAILER COUPLER

## INSTALLATION INSTRUCTIONS

1. Bolt coupler to front of trailer tongue using the largest possible bolts that will fit through coupler side holes. Use all available side holes. Additional bolts may be used in top holes for extra strength if desired. Do not drill or otherwise enlarge or modify any mounting holes.
2. If coupler is to be welded to trailer tongue, care must be taken to get good penetration without undercutting either coupler or tongue. Weld at least entire bottom edge of both sides.

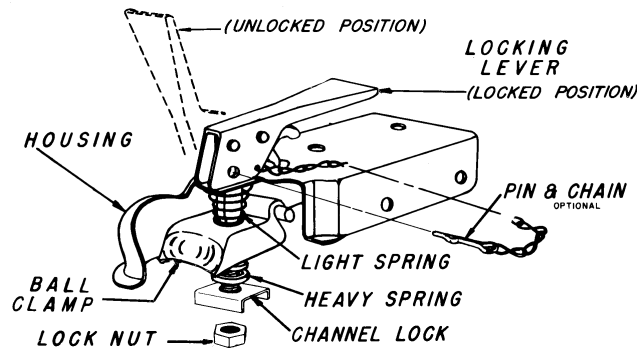

## ASSEMBLY INSTRUCTIONS

1. Assemble all parts as shown in the diagram above. Note that locking lever must be in the unlocked position when assembling.
2. Adjust coupler to ball by raising channel lock and turning nut with fingers. Proper adjustment is obtained when coupler is as tight as possible on ball and locking lever can still be opened and closed. Check adjustment frequently and tighten if necessary.

## OPERATION INSTRUCTIONS

Use only with specified ball size.

To Unlock – Pull locking trigger upward with index finger and lift locking lever.

To Lock – Push locking lever handle down. The optional locking pin or a pad-lock may be inserted in the locking lever hole for extra security.

**WARNING:** Every time coupler is used, make certain ball is completely engaged in socket and coupler is securely locked. Failure to do so could result in serious or fatal injury.

**Safety chains must be used.** Cross safety chains under coupling allowing only enough slack for turns.

## MAINTENANCE & REPAIR INSTRUCTIONS

1. Do not use coupler with any bent or otherwise damaged parts. Repair kits are available which contain all parts except the housing.

**WARNING:** These component parts should not be interchanged with the component parts of any other Dutton-Lainson Company model or other manufacturer's couplers.

<b>SAE CLASS 1</b> MODELS 940-1, 950-1, 960-1 & 970-1 For gross trailer weights up to 2,000 lb/908 kg. Max. Tongue Wt. 200 lb (90 kg.) Repair Kit No. 6256	<b>SAE CLASS 2</b> MODELS 980-2, 981-2 & 982-2 For gross trailer weights up to 3,500 lb/1589 kg. Max. Tongue Wt. 300 lb (136 kg.) Repair Kit No. 6257	<b>SAE CLASS 3</b> MODEL 985-3 For gross trailer weights up to 5,000 lb/2270 kg. Max. Tongue Wt. 15% GTW Repair Kit No. 6257
---	--	--

*This product complies with SAE J684 and VESC V-5 Standards.  
U.S. Pat. 6481740 B1*

For added trailer security, use Model 6298 D-L Hitch-Lock® Trailer Guard.  
Available at most trailer and towing departments.



SINCE 1886

MANUFACTURED BY

**DUTTON-LAINSON COMPANY**  
Hastings, Nebraska 68902-0729 • 402-462-4141 • FAX 402-460-4612

MADE IN U.S.A.

Dwg. No. 203013M 503

©1998/2003 CORNHUSKER PRESS

## Installation Instructions for Class 2, Class 3, and 34600/34318 Class 4 Couplers

### Weld on Instructions

- Use 1/8" fillet weld as shown below. Use No. E6011 A.W.S. Welding Rod (AC RO DCAP) 1/8" Dia. Set machine AMPS at 105/115 with 18/22 volts.

**⚠ CAUTION ⚠**

After installation is complete, check that coupler operation has not been impaired in any way.

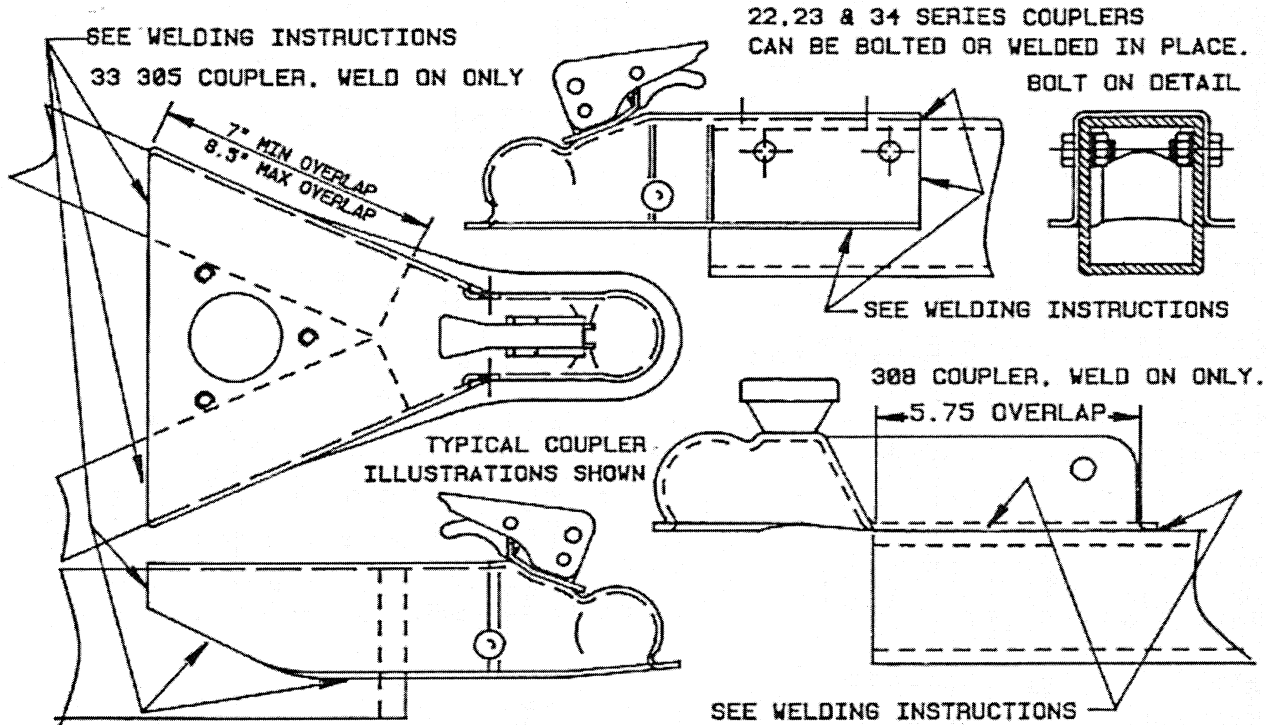

### Bolt on Instructions

1. Assure coupler internal stop is butted against end of trailer tongue for maximum overlap.
2. The preferred method is to use (4) 1/2" bolts through side holes and torqued to 30/35 ft. lbs. (see illustration below) An alternate method is to use (2) 1/2" grade 5 through bolts and locknuts providing they can be torqued to at least 35 ft. lbs. without excessive deformation of the coupler or the trailer tongue.

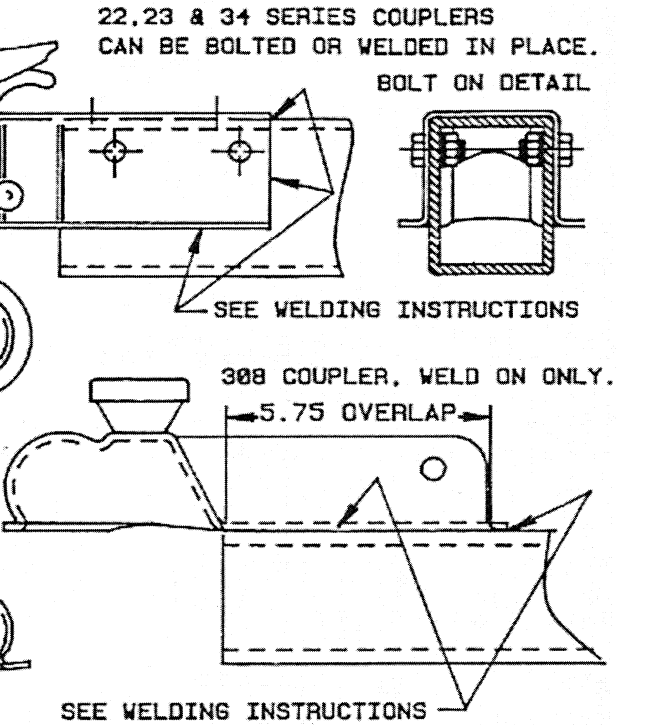

COUPLER REPAIR KITS			
Kit No.	Description	Ball Dia.	Illustration
32-0801	Kit for 506, B-6, 308, B-8 Couplers	2 7/8"	A
34-0801	Kit for 1-509, H-Series Couplers	1-7/8"	B
58-0801	Kit for 107, 108, 07 & 08 Couplers	1-7/8"	C
61-0801	Kit for 34-308 Couplers	2"	D
62-0801	Kit for 34-318 Couplers	2"	D
58-0801	Kit for 11 and 1 Series Fas-Lok Couplers	1-7/8"	E
99-0801	Kit for 22 and 2 Series Fas-Lok Couplers	2"	F
60-0801	Kit for 34-300, 33-305 Couplers	2"	G
65-0801	Kit for 22 Series Handwheel Couplers	2"	H
61-0801	Kit for 34-600 Couplers	2"	I

**FOLLOW COMPONENT ASSEMBLY SEQUENCE SHOWN BELOW.**

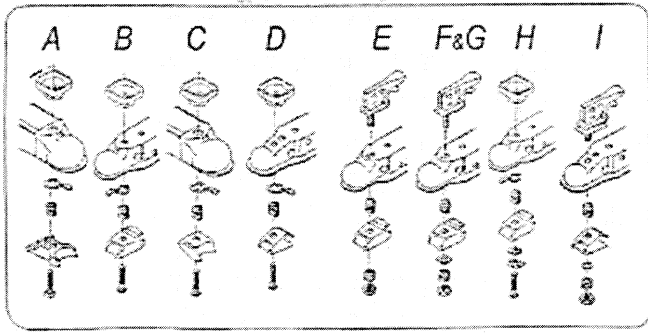

**⚠ DANGER ⚠**

If housing is deformed, replace complete coupler. Use only genuine Fulton repair kits.

**⚠ DANGER ⚠**

When assembling the coupler make sure the ball clamp is located properly onto the housing rivet as shown below for your style of coupler.

### Adjustment method for Fas-Lok Couplers

With the assembled coupler clamped onto the correct size ball, turn the locknut down just until the spring under the locknut is fully compressed. Then back the locknut off 1/2 to one turn or just enough to enable clamping or unclamping the coupler and ball.

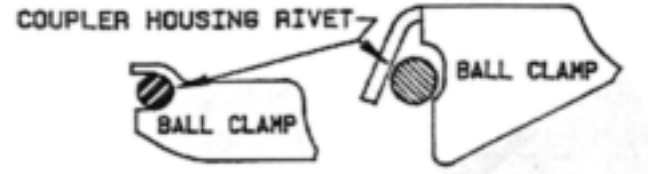

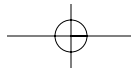

## Hubs, Bearings, Races and Seals

Karavan Trailers uses the following sizes of hubs on all of its model trailers. Measurements listed are both spindle size and hub size.

Hub Size	Bearing, Race & Seal Size	Manufacturer's Number
1-1/16"	Inner & Outer Bearing 1-1/16"	L-44649
5-1/2" flange	Inner & Outer Race 1-1/16"	L-44610
	Spring loaded dust seal (1.250 I.D.-1.985 O.D.)	12192 TB
Chevron Starplex EP2	Dexter Torsion Axle	
	Spring loaded dust seal (1.500 I.D.-1.985 O.D.)	15192 TB
1-3/8"-1-1/16"	Inner Bearing 1-3/8"	L-68149
5 Bolt UHI	Inner Race 1-3/8"	L-68110
10" Brake Drums	Outer Bearing 1-1/16"	L-44649
	Outer Race 1-1/16"	L-44610
	Spring loaded dust seal (1.750 I.D.-2.565 O.D.)	17255 TB
1-3/4"-1-1/4"	Inner Bearing 1-3/4"	25580
6 Bolt UHI	Inner Race 1-3/4"	25520
12" Brake Drums	Outer Bearing 1-1/4"	L-15123
	Outer Race 1-1/4"	L-15245
	Spring loaded dust seal (2.125 I.D.-3.38 O.D.)	21333 TB

## Grease Seals

Inspect the grease seals periodically. A visual inspection is sufficient and is done quite easily on a trailer without brakes. It is normal to see a small oil film around the seal area. This should not hurt anything. However if the leakage becomes excessive it is time to replace the seal before too much grease escapes causing bearing failure. Replacement of the seal requires removing the complete hub assembly from the spindle.

On axles with brakes you must remove the complete brake drum assembly to inspect the seals. It is **very important** that you check the seals on brake axles periodically to make sure they are not leaking. Leaking seals allow the grease to get on the brake linings thus causing grabby brakes. Eventually the brake linings will become saturated with grease and will have to be replaced.

**\*\*Please note** that some Karavan Trailer models are equipped with Knott-AutoFlex Waterproof bearings that require no maintenance. DO NOT remove the metal cap for any reason or damage could result to the bearings. The caps have KNOTT-WATERPROOF stamped in them.

## Karavan's Sure Lube System

Karavan uses a Sure Lube system on all of its axles. This system is a well accepted benefit for trailering.

Under the rubber dust cap there is a grease zerk. The grease zerk presses into the hole that goes all the way through the center of the spindle and comes out by the back bearing. At that point it greases the back bearing and fills the inside of the hub. It then greases your front bearing. When you see grease come out by the castle nut, your hub and bearing are full.

## Advantages of the Sure Lube System

1. You can grease the bearings without taking the hubs off.
2. You can change the grease in your hub and bearings by rotating the hub slowly while putting grease in, until you see new grease come out.
3. You can check your hub & grease at any time.
4. You can grease your bearing at any time on long trips.

## Maintenance of Sure Lube

1. Once or twice a year (depending on usage) jack your trailer up one wheel at a time. Hold the wheel with both hands and try to rock to check for play in the bearing. If you have play then you need to adjust your castle nut (see bearing adjustment).
2. When greasing bearings look at the old grease when it comes out. If you see small silver like filings it may indicate a problem with your bearings. They should be replaced immediately.
3. It is important to use a pin the same size as the hole to make your Sure Lube system work properly.

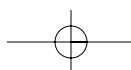

## When to Check

Trailers often sit idle for extended periods of time so it is a good idea to check all of these before any use. Bearings rechecked and repacked before storage and after immersion in salt water will last longer.

Check the lubricant level when the hub is warm. On boat trailers, we suggest that you check just prior to launching to be sure the hub is full of grease when the axle is submerged.

## Recommended Lubricant

Chevron Starplex EP2 Grease is installed at the factory. Any good marine grade water-resistant grease is recommended. Different types of grease thickeners should not be mixed

## Bearing Repacking

Ideally, one would not have to be concerned about wheel bearings in that you would not have to get them submerged in the water when loading and unloading. This is not the case in many instances so therefore preventative maintenance is required. This type of maintenance varies so greatly because one individual may back his trailer in and out of the water 300 times a year and tow it 1,500 miles total while another individual may back his in the water six times a year but tow it 7,000 miles. Then we also have an individual that hauls his boat 30 miles, puts it in the water for the summer, and then loads it back up in the fall for the 30 mile trip home.

Because of the various types of ways in which people use a trailer it becomes difficult to say every 500 miles repack your bearings or after backing in the water 10 times repack your bearings. Neither of the above can apply.

About the only thing that applies is good common sense.

### Note the following:

1. When water gets in the bearings and is on the steel itself it will rust. So the most important part is get a good grade of wheel bearing grease that will not break down when water is mixed with it.
2. Pack the bearings by forcing the grease into all the small cavities in the bearings. Fill the cavity in the hub with grease.
3. Make sure the grease seals are in usable condition.
4. Keep the bearings and grease free of any dirt or foreign matter.
5. The wheel bearings should be repacked anytime during the year that you plan on storing the trailer for a period of time.
6. The more often you back your trailer in the water, the more chance you stand of getting water in the bearings. You should definitely be packing your bearings more often (at least twice during the season) if this is the situation.
7. Towing a trailer numerous miles has its good points and bad points. Long towings may warm the hub and grease up enough to remove any water it may have collected. However should you then back the warm hubs into the water just after a long tow they will take on water through condensation. It is therefore important that you let them cool before backing into the water.
8. Be sure the bearings are adjusted properly not too tight, or too loose. See Bearing Adjustment.

Check the grease in your hubs once a year. In most instances, if a good quality lubricant is used and the lubricant levels are maintained, it may not be necessary to repack the bearings. However, should the grease appear to be contaminated or broken down, remove all of the old grease from the bearings and hubs and completely repack. Remove the rear bearing will most likely cause damage to the rear seal. A new one should be installed when reassembling.

## Bearing Adjustment

The wheel bearings have been preadjusted at the factory. To maximize bearing life, however, we suggest that you check the bearing adjustment after the first 50 miles of use, then every time the bearings are repacked.

Bearing adjustment can be checked by jacking up one side of the trailer. Grip the edge of the wheel and see if you can rock it or move it. If you have movement remove the dust cap and the cotter key. While rotating wheel tighten the spindle nut to a recommended 20 inch-pounds of torque if your trailer has 1-1/16" - 1-1/16" bearings or 30 inch-pounds if your trailer has 1-3/8" - 1-1/16" bearings. Do not over tighten. Look for the hole in the spindle through the slots in the spindle nut. If you can see any part of the hole through the slot in the nut turn the nut counterclockwise until the next slot in the nut lines up with the cross hole. Insert cotter key or new L pin.

If you cannot see any portion of the hole in the spindle through the slots in the nut, turn the nut counterclockwise until the hole lines up with the first slot available in the nut. Insert cotter key or L pin.

This adjustment will give you from one-thousandths to ten thousandths end play, which is in tolerance for proper adjustment. Check wheel again for the movement. If no movement, spin wheel. Wheel should turn easily and have no end play (lateral movement). Bend ends of cotter key or L pin to keep it from coming off. A large cotter pin must be used to fill the hole for the sure lube system to work properly. Position dust cover. Tap lightly on edges to start cover. Then using a screwdriver and alternating sides as you work around the dust cover, tap screwdriver with hammer until the dust cover is completely into the hub and the flange on the dust cover is tight against the hub face. Repeat on other wheels.



## Lighting & Wiring Diagram & Color Code

Make sure that all trailer lights are in proper working order.

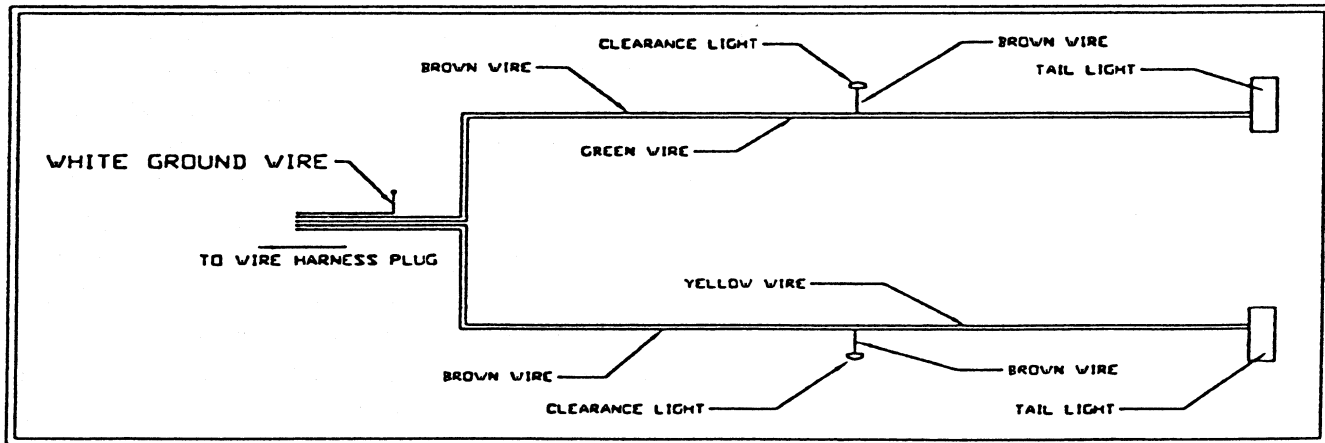

Yellow Wire - Left Stop & Turn  
Green Wire - Right Stop & Turn  
Brown Wire - Taillights, Rear Marker Lights, Front & Rear Side Lights  
White Wire - Ground

State and Federal regulations require all types of trailers to be equipped with tail, stop, turn and side marker lights. Trailers over 80 inches wide must have clearance and identification lights. All the necessary lights are supplied by us, the manufacturer, however it is the owner's responsibility to maintain them in good operating condition at all times.

Make sure the ground wire is attached to both the trailer and towing vehicle to make a sure, positive ground. Some towing vehicles are equipped with a 4-wire taillight systems. It then becomes necessary to use a four to a three wire converter.

## Troubleshooting and Maintenance

The Karavan electrical system is quite trouble-free especially with the use of the automotive type wire harness that we use. This eliminates shorts in the system due to bad or corroded connections. We suggest however that you use the following precautions for trouble-free trailering:

1. Disconnect the tongue harness from the towing vehicle before backing the trailer into the water. This will eliminate the bulbs from lighting while submerged in the water. Lighting submerged light bulb will cause it to burn out. (This is not necessary if your unit is equipped with waterproof taillights and rear cluster).
2. Carry a spare taillight bulb #1157, which is the large bulb in the taillight. The smaller bulb in the taillight for the sidelight is #57, and is also used in the rectangular amber sidelight.
3. Once a year remove the light lenses and spray or coat the metal components with either WD40 or CRC. A light coat of petroleum jelly also works quite well so that the metal doesn't rust and makes water run right off.
4. Make sure your towing vehicle's electrical system is sufficient to handle the extra load required to power your trailer lights. Check with your local automotive dealer for specifications and any options available to increase the electrical capacity.
5. In order to insure a positive ground connection between the trailer and the towing vehicle, it is important that the white ground wires are secured properly to both the trailer and the towing vehicle. A poor ground connection will cause the taillights to blink and not function properly.

## Load-Carrying Capacity

The serial tag will show the Gross Vehicle Weight Rating (GVWR) which is the load-carrying capacity plus the weight of the trailer itself. NOTE: This trailer is equipped to meet applicable Federal safety standards. Check local and state requirements regarding brakes and any additional equipment that may be required. Any modifications or additions including load equalizing hitches, without written factory consent; usage in an abnormal manner including overloading voids all manufacturers warranties and liability.

5KTPS29208F190247



LTPB-2225-35

5KTPS29208F190247

**MED BY/FABRIQUE PAR: KARAVAN TRAILERS, INC**

<b>DATE:</b> August 2007		<b>MADE IN USA</b>		<b>JOB#</b> 122180	
PNBV / GVWR		ALL AXLES PNBE / GAWR		COLD INFL. MAX. LOAD PRESSURE CARRYING	
KG	LB	KG	LB	KPA	PSI
1996	4400	1996	4400	345	50
		TIRE/PNEU		RIM	
		ST175/80D13		1588 3500	

THIS VEHICLE CONFORMS TO ALL APPLICABLE U.S. FEDERAL MOTOR VEHICLE SAFETY STANDARDS (FMVSS) IN EFFECT ON THE DATE OF MANUFACTURE SHOWN ABOVE. THIS VEHICLE CONFORMS TO ALL APPLICABLE STANDARDS PRESCRIBED UNDER THE CANADIAN MOTOR VEHICLE SAFETY REGULATIONS IN EFFECT ON THE DATE OF MANUFACTURE SHOWN ABOVE. / CE VEHICULE EST CONFORME A TOUTES LES NORMES QUI LUI SONT APPLICABLES EN VERTU DU REGLEMENT SUR LA SECURITE DES VEHICULES AUTOMOBILES DU CANADA EN VIGUEUR A LA DATE DE SA FABRICATION.

**TYPE:** PONTOON TRAILER **LTPB-2225-35**



### TIRE AND LOADING INFORMATION

The combined weight of occupants and cargo should never exceed **1588 KG or 3500LB**

TIRE	SIZE	COLD TIRE PRESSURE	<b>SEE OWNER'S MANUAL FOR ADDITIONAL INFORMATION</b>
FRONT	ST175/80D13C	345 kPa 50 PSI	
REAR			
SPARE	NONE		

## Paint and its Care

The finish on your Karavan Trailer is a powder-painted, baked finish. It is a finish, when properly maintained, should remain very eye appealing for years. Touch up paint is available in a bottle with a paint stick or a spray can. All nicks and scratches should be touched up before rusting sets in and starts to deteriorate the finish.

Should the trailer become exposed to salt water or towing on salted highways we recommend that you flush it with soap and water as soon as possible. Salt is very harsh on any type of finish and deteriorates it very rapidly.

## Recommended Torquing Procedure for Mounting Wheels

### WARNING:

Maintain proper torque on lug nuts or wheel bolts. Failure to do so may result in serious injury or property damage.

1. After dismantling old wheel, remove all dirt, rust, grease and oil from stud threads. Do not lubricate threads.
2. Position wheel on trailer. Inspect to insure full contact between mounting surface (seat pads) of wheel and mounting surface of hub or brake drum.
3. Start wheel nuts on studs.
4. Finger tighten top nut, then rotate wheel so that the number 2 nut is at top and finger tighten. Finger tighten remaining nuts in numerical (crisscross) order; always tighten nuts in top position.
5. Repeat Step 4, rotating wheel and finger tightening nuts until all nuts are snug.
6. Tighten nuts in same fashion as described in Steps 4 and 5. Nuts should be torqued to 80-90 ft. lbs. Retorque nuts after 50 miles of driving and periodically thereafter.
7. After wheels (with tires) have been mounted, visually inspect to insure noninterference with body or other component parts. Be sure to inspect wheels in all possible positions (extreme turns, etc).

NOTE : Check the fit of your lug wrench, an oversize wrench results in mutilated lug nuts.

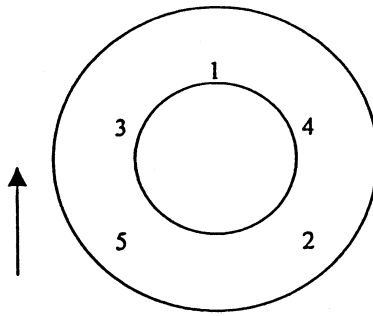

## Changing Tire

It is desirable that you carry a jack that will work on your trailer in the event that you have a flat tire. A small board or block can also be very beneficial in the event you are jacking on soft dirt or hot asphalt. the jack (depending on style) may be placed under the side frame in back of the wheel or also under the axles.

## Safety Chains

### CAUTION:

Avoid sharp turns. This could bend, create extreme stress or fracture either the coupler or the trailer tongue.

The safety chains on your unit are an added insurance that it will not become detached from the towing vehicle. Your trailer hitch on the towing vehicle should have two holes or rings for fastening the safety chains, preferably one on each side of ball hitch. It is strongly recommended that you crisscross the chains under the tongue, the chain on the left side of the trailer attached to hole or ring on the right side of the ball hitch, and vice versa. This prevents the trailer tongue from dropping to the road should the coupler or ball hitch fail. The chains should be rigged as tight as possible with just enough slack to allow tight turns to be made. This can be accomplished by twisting the chain hook in a clockwise or counterclockwise direction thus twisting the link spacings and making the chain shorter. Also by keeping your chains as short as possible you prevent them from dragging on the road and wearing the chain links. **NOTE:** *If for any reason you find it necessary to replace a safety chain, do not use or substitute any lighter weight chain than supplied with your trailer. All chain attachments such as hooks, s-hooks, etc. must be equally as strong as the chain itself.*

**WARNING:**

**AVOID ACCIDENTS -- BEFORE TRAILERING**

**HITCH ONLY TO BALL SIZE MARKED ON COUPLING**

**BE CERTAIN BALL CLAMP CAPTURES BALL AND LEVER OR HANDWHEEL IS FULLY CLAMPED**

**CROSS SAFETY CHAINS UNDER COUPLING**

**ALLOW ONLY ENOUGH SLACK FOR TURNS**

Trailer Class	Trailer Weight GVWR in Pounds	Minimum Braking Strength in Pounds
II	1,000 to 3,500	3,500
III	3,500 to 5,000	5,000
IV	5,000 to 7,600	7600
V	7,600 to 16,200	16200

## Tie Downs

It is very important that your recreational vehicle is supported properly by the trailer. It is also important that your recreational vehicle stays positioned on the trailer while towing. This is accomplished by securing your load to the trailer by some type of tie down.

1 Bow Tie Down: Karavan Trailers offers one of the best winch post assemblies as far as adjustment and stability are concerned. However for added security, you may want to use a separate tie down to tie the bow eye both downward and also forward. This should guard against any sudden stops or starts. This also guards against winch or winch strap failure (on Boat Trailers).

2 Rear Tie Down: It is very important that the transom of your boat is resting fully and securely on the supports provided and that it remains that way while trailering. The two most common types of tie downs are the transom tie down strap or else the gunwale tie down. Either system works well and holds your boat solidly on the trailer. Places to fasten the gunwale tie downs are provided in either the light brackets or the side frame brackets (on Boat Trailers).

## Tires & Tire Pressure

The most common cause of trailer tire trouble is under-inflation. It is important therefore that you always maintain full air pressure, as indicated by the tire manufacturer on the tire's sidewalls or on the trailer manufacturer's certification label.

Always check air pressure when the tires are cold, before you've moved the trailer. Tires heat up and the air pressure increases after traveling only a short distance.

When your trailer tires become worn or damaged, replace them promptly with the same type, size and capacity (not necessarily the same brand) as the original tires. For example: some trailers are not designed for use with radial tires. If the original tires on your trailer were not radials, do not replace them with radials (radials can be used as long as they have the proper carrying capacity).

For safety and convenience, it is recommended that you always carry a spare wheel and tire. Check your state laws in regards to spare wheels, most states require you to carry a spare at all times.

Most tire manufacturers have the air pressure molded on the tire sidewall. Listed below are examples of tire sizes with their respective carrying capacities and tire pressures, but your particular tire may not be listed.

### Bias-Ply Tires

Tire Size	Load Range	Ply Rating	Max Load lbs.	Inflation P.S.I. Cold
4.80 x 8	B	4	590	60
4.80 x 12	B	4	780	60
4.80 x 12	C	6	990	90
5.30 x 12	B	4	840	55
5.30 x 12	C	6	1045	80
5.70 x 8	B	4	715	50
5.70 x 8	C	6	910	75
ST175/80D-13	B	4	1100	35
ST175/80D-13	C	6	1360	50
ST205/75D-14	B	4	1430	35
ST205/75D-14	C	6	1760	50
ST215/75D-14	C	6	1870	50
ST225/75D-15	C	6	2150	50
ST225/75D	D	8	2540	65
7.50 x 16	E	10	2780	75
16.5 x 8	B	4	620	45
18.5 x 8	B	4	780	35
18.5 x 8	C	6	935	50
20.5 x 8.0 x 10	C	6	1105	50
20.5 x 8.0 x 10	E	10	1520	90
20.5 x 8.0 x 10	F	12	1650	105

### Radial Tires

Tire Size	Load Range	Ply Rating	Max Load lbs.	Inflation P.S.I. cold
ST175/80R-13	C	6	1355	50
ST205/75R-14	C	6	1763	50
ST215/75R-14	C	6	1823	50

### Important

Many tire manufacturers have toll free numbers, which you may call should you have a problem with one of their products. (See inside front cover).

# 1. TIRE SAFETY INFORMATION

This portion of the User's Manual contains tire safety information as required by 49 CFR 575.6.

Section 2.1 contains "Steps for Determining Correct Load Limit - Trailer".

Section 2.2 contains "Steps for Determining Correct Load Limit – Tow Vehicle".

Section 2.3 contains a Glossary of Tire Terminology, including "cold inflation pressure", "maximum inflation pressure", "recommended inflation pressure", and other non-technical terms.

Section 2.4 contains information from the NHTSA brochure entitled "Tire Safety – Everything Rides On It".

This brochure, as well as the preceding subsections, describes the following items;

- Tire labeling, including a description and explanation of each marking on the tires, and information about the DOT Tire Identification Number (TIN).
- Recommended tire inflation pressure, including a description and explanation of:
  - A. Cold inflation pressure.
  - B. Vehicle Placard and location on the vehicle.
  - C. Adverse safety consequences of under inflation (including tire failure).
  - D. Measuring and adjusting air pressure for proper inflation.
- Tire Care, including maintenance and safety practices.
- Vehicle load limits, including a description and explanation of the following items:
  - A. Locating and understanding the load limit information, total load capacity, and cargo capacity.
  - B. Calculating total and cargo capacities with varying seating configurations including quantitative examples showing / illustrating how the vehicles cargo and luggage capacity decreases as combined number and size of occupants' increases. This item is also discussed in Section 3.
  - C. Determining compatibility of tire and vehicle load capabilities.
  - D. Adverse safety consequences of overloading on handling and stopping on tires.

## 1.1. STEPS FOR DETERMINING CORRECT LOAD LIMIT – TRAILER

Determining the load limits of a trailer includes more than understanding the load limits of the tires alone. On all trailers there is a Federal certification/VIN label that is located on the forward half of the left (road) side of the unit. This certification/VIN label will indicate the trailer's Gross Vehicle Weight Rating (GVWR). This is the most weight the fully loaded trailer can weigh. It will also provide the Gross Axle Weight Rating (GAWR). This is the most a particular axle can weigh. If there are multiple axles, the GAWR of each axle will be provided.

If your trailer has a GVWR of 10,000 pounds or less, there is a vehicle placard located in the same location as the certification label described above. This placard provides tire and loading information. In addition, this placard will show a statement regarding maximum cargo capacity. Cargo can be added to the trailer, up to the maximum weight specified on the placard. The combined weight of the cargo is provided as a single number. In any case, remember: the total weight of a fully loaded trailer can not exceed the stated GVWR.

For trailers with living quarters installed, the weight of water and propane also need to be considered. The weight of fully filled propane containers is considered part of the weight of the trailer before it is loaded with cargo, and is not considered part of the disposable cargo load. Water however, is a disposable cargo weight and is treated as such. If there is a fresh water storage tank of 100 gallons, this tank when filled would weigh about 800 pounds. If more cargo is being transported, water can be off-loaded to keep the total amount of cargo added to the vehicle within the limits of the GVWR so as not to overload the vehicle. Understanding this flexibility will allow you, the owner, to make choices that fit your travel needs.

When loading your cargo, be sure it is distributed evenly to prevent overloading front to back and side to side. Heavy items should be placed low and as close to the axle positions as reasonable. Too many items on one side may overload a tire. The best way to know the actual weight of the vehicle is to weigh it at a public scale. Talk to your dealer to discuss the weighing methods needed to capture the various weights related to the trailer. This would include the weight empty or unloaded, weights per axle, wheel, hitch or king-pin, and total weight.

Excessive loads and/or underinflation cause tire overloading and, as a result, abnormal tire flexing occurs. This situation can generate an excessive amount of heat within the tire. Excessive heat may lead to tire failure. It is the air pressure that enables a tire to support the load, so proper inflation is critical. The proper air pressure may be found on the certification/VIN label and/or on the Tire Placard. This value should never exceed the maximum cold inflation pressure stamped on the tire.

### 1.1.1. TRAILERS 10,000 POUNDS GVWR OR LESS

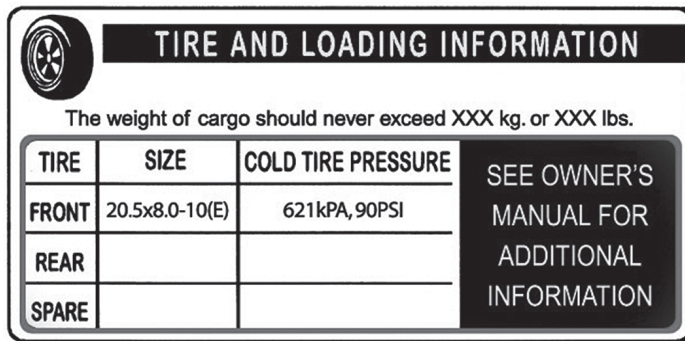

The weight of cargo should never exceed XXX kg. or XXX lbs.

TIRE	SIZE	COLD TIRE PRESSURE	SEE OWNER'S MANUAL FOR ADDITIONAL INFORMATION
FRONT	20.5x8.0-10(E)	621kPA, 90PSI	
REAR			
SPARE			

*Tire and Loading Information  
Placard - Figure 1-1*

1. Locate the statement, "The weight of cargo should never exceed XXX kg or XXX lbs.," on your vehicle's placard. See figure 1-1.
2. This figure equals the available amount of cargo and luggage load capacity.
3. Determine the combined weight of luggage and cargo being loaded on the vehicle. That weight may not safely exceed the available cargo and luggage load capacity.

The trailer's placard refers to the Tire Information Placard attached adjacent to or near the trailer's VIN (Certification) label at the left front of the trailer.

### 1.1.2. TRAILERS OVER 10,000 POUNDS GVWR (NOTE: THESE TRAILERS ARE NOT REQUIRED TO HAVE A TIRE INFORMATION PLACARD ON THE VEHICLE)

1. Determine the empty weight of your trailer by weighing the trailer using a public scale or other means. This step does not have to be repeated.
2. Locate the GVWR (Gross Vehicle Weight Rating) of the trailer on your trailer's VIN (Certification) label.
3. Subtract the empty weight of your trailer from the GVWR stated on the VIN label. That weight is the maximum available cargo capacity of the trailer and may not be safely exceeded.

### 1.2. STEPS FOR DETERMINING CORRECT LOAD LIMIT - TOW VEHICLE

1. Locate the statement, "The combined weight of occupants and cargo should never exceed XXX lbs.," on your vehicle's placard.
2. Determine the combined weight of the driver and passengers who will be riding in your vehicle.
3. Subtract the combined weight of the driver and passengers from XXX kilograms or XXX pounds.
4. The resulting figure equals the available amount of cargo and luggage capacity. For example, if the "XXX" amount equals 1400 lbs. and there will be five 150 lb. passengers in

your vehicle, the amount of available cargo and luggage capacity is 650 lbs. (1400-750 (5 x 150) = 650 lbs.).

5. Determine the combined weight of luggage and cargo being loaded on the vehicle. That weight may not safely exceed the available cargo and luggage capacity calculated in Step # 4.
6. If your vehicle will be towing a trailer, load from your trailer will be transferred to your vehicle. Consult the tow vehicle's manual to determine how this weight transfer reduces the available cargo and luggage capacity of your vehicle.

### 1.3. GLOSSARY OF TIRE TERMINOLOGY

#### **Accessory weight**

The combined weight (in excess of those standard items which may be replaced) of automatic transmission, power steering, power brakes, power windows, power seats, radio and heater, to the extent that these items are available as factory-installed equipment (whether installed or not).

#### **Bead**

The part of the tire that is made of steel wires, wrapped or reinforced by ply cords and that is shaped to fit the rim.

#### **Bead separation**

This is the breakdown of the bond between components in the bead.

#### **Bias ply tire**

A pneumatic tire in which the ply cords that extend to the beads are laid at alternate angles substantially less than 90 degrees to the centerline of the tread.

#### **Carcass**

The tire structure, except tread and sidewall rubber which, when inflated, bears the load.

#### **Chunking**

The breaking away of pieces of the tread or sidewall.

#### **Cold inflation pressure**

The pressure in the tire before you drive.

#### **Cord**

The strands forming the plies in the tire.

#### **Cord separation**

The parting of cords from adjacent rubber compounds.

#### **Cracking**

Any parting within the tread, sidewall, or inner liner of the tire extending to cord material.

#### **CT**

A pneumatic tire with an inverted flange tire and rim system in which the rim is designed with rim flanges pointed radially inward and the tire is

designed to fit on the underside of the rim in a manner that encloses the rim flanges inside the air cavity of the tire.

**Curb weight**

The weight of a motor vehicle with standard equipment including the maximum capacity of fuel, oil, and coolant, and, if so equipped, air conditioning and additional weight optional engine.

**Extra load tire**

A tire designed to operate at higher loads and at higher inflation pressures than the corresponding standard tire.

**Groove**

The space between two adjacent tread ribs.

**Gross Axle Weight Rating**

The maximum weight that any axle can support, as published on the Certification / VIN label on the front left side of the trailer. Actual weight determined by weighing each axle on a public scale, with the trailer attached to the towing vehicle.

**Gross Vehicle Weight Rating**

The maximum weight of the fully loaded trailer, as published on the Certification / VIN label. Actual weight determined by weighing trailer on a public scale, without being attached to the towing vehicle.

**Hitch Weight**

The downward force exerted on the hitch ball by the trailer coupler.

**Innerliner**

The layer(s) forming the inside surface of a tubeless tire that contains the inflating medium within the tire.

**Innerliner separation**

The parting of the innerliner from cord material in the carcass.

**Intended outboard sidewall**

The sidewall that contains a white-wall, bears white lettering or bears manufacturer, brand, and/or model name molding that is higher or deeper than the same molding on the other sidewall of the tire or the outward facing sidewall of an asymmetrical tire that has a particular side that must always face outward when mounted on a vehicle.

**Light truck (LT) tire**

A tire designated by its manufacturer as primarily intended for use on lightweight trucks or multipurpose passenger vehicles.

**Load rating**

The maximum load that a tire is rated to carry for a given inflation pressure.

**Maximum load rating**

The load rating for a tire at the maximum permissible inflation pressure for that tire.

**Maximum permissible inflation pressure**

The maximum cold inflation pressure to which a tire may be inflated.

**Maximum loaded vehicle weight**

The sum of curb weight, accessory weight, vehicle capacity weight, and production options weight.

**Measuring rim**

The rim on which a tire is fitted for physical dimension requirements.

**Pin Weight**

The downward force applied to the 5<sup>th</sup> wheel or gooseneck ball, by the trailer kingpin or gooseneck coupler.

**Non-pneumatic rim**

A mechanical device which, when a non-pneumatic tire assembly incorporates a wheel, supports the tire, and attaches, either integrally or separately, to the wheel center member and upon which the tire is attached.

**Non-pneumatic spare tire assembly**

A non-pneumatic tire assembly intended for temporary use in place of one of the pneumatic tires and rims that are fitted to a passenger car in compliance with the requirements of this standard.

**Non-pneumatic tire**

A mechanical device which transmits, either directly or through a wheel or wheel center member, the vertical load and tractive forces from the roadway to the vehicle, generates the tractive forces that provide the directional control of the vehicle and does not rely on the containment of any gas or fluid for providing those functions.

**Non-pneumatic tire assembly**

A non-pneumatic tire, alone or in combination with a wheel or wheel center member, which can be mounted on a vehicle.

**Normal occupant weight**

This means 68 kilograms (150 lbs.) times the number of occupants specified in the second column of Table I of 49 CFR 571.110.

**Occupant distribution**

The distribution of occupants in a vehicle as specified in the third column of Table I of 49 CFR 571.110.

**Open splice**

Any parting at any junction of tread, sidewall, or innerliner that extends to cord material.

**Outer diameter**

The overall diameter of an inflated new tire.

**Overall width**

The linear distance between the exteriors of the sidewalls of an inflated tire, including elevations due to labeling, decorations, or protective bands or ribs.

**Ply**

A layer of rubber-coated parallel cords.

**Ply separation**

A parting of rubber compound between adjacent plies.

**Pneumatic tire**

A mechanical device made of rubber, chemicals, fabric and steel or other materials, that, when mounted on an automotive wheel, provides the traction and contains the gas or fluid that sustains the load.

**Production options weight**

The combined weight of those installed regular production options weighing over 2.3 kilograms (5 lbs.) in excess of those standard items which they replace, not previously considered in curb weight or accessory weight, including heavy duty brakes, ride levelers, roof rack, heavy duty battery, and special trim.

**Radial ply tire**

A pneumatic tire in which the ply cords that extend to the beads are laid at substantially 90 degrees to the centerline of the tread.

**Recommended inflation pressure**

This is the inflation pressure provided by the vehicle manufacturer on the Tire Information label and on the Certification / VIN tag.

**Reinforced tire**

A tire designed to operate at higher loads and at higher inflation pressures than the corresponding standard tire.

**Rim**

A metal support for a tire or a tire and tube assembly upon which the tire beads are seated.

**Rim diameter**

This means the nominal diameter of the bead seat.

**Rim size designation**

This means the rim diameter and width.

**Rim type designation**

This means the industry of manufacturer's designation for a rim by style or code.

**Rim width**

This means the nominal distance between rim flanges.

**Section width**

The linear distance between the exteriors of the sidewalls of an inflated tire, excluding elevations due to labeling, decoration, or protective bands.

**Sidewall**

That portion of a tire between the tread and bead.

**Sidewall separation**

The parting of the rubber compound from the cord material in the sidewall.

**Special Trailer (ST) tire**

The "ST" is an indication the tire is for trailer use only.

**Test rim**

The rim on which a tire is fitted for testing, and may be any rim listed as appropriate for use with that tire.

**Tread**

That portion of a tire that comes into contact with the road.

**Tread rib**

A tread section running circumferentially around a tire.

**Tread separation**

Pulling away of the tread from the tire carcass.

**Treadwear indicators (TWI)**

The projections within the principal grooves designed to give a visual indication of the degrees of wear of the tread.

**Vehicle capacity weight**

The rated cargo and luggage load plus 68 kilograms (150 lbs.) times the vehicle's designated seating capacity.

**Vehicle maximum load on the tire**

The load on an individual tire that is determined by distributing to each axle its share of the maximum loaded vehicle weight and dividing by two.

**Vehicle normal load on the tire**

The load on an individual tire that is determined by distributing to each axle its share of the curb weight, accessory weight, and normal occupant weight (distributed in accordance with Table I of CRF 49 571.110) and dividing by 2.

**Weather side**

The surface area of the rim not covered by the inflated tire.

**Wheel center member**

In the case of a non-pneumatic tire assembly incorporating a wheel, a mechanical device which attaches, either integrally or separably, to the non-pneumatic rim and provides the connection between the non-pneumatic rim and the vehicle; or, in the case of a non-pneumatic tire assembly not



incorporating a wheel, a mechanical device which attaches, either integrally or separably, to the non-pneumatic tire and provides the connection between tire and the vehicle.

#### **Wheel-holding fixture**

The fixture used to hold the wheel and tire assembly securely during testing.

### **1.4. TIRE SAFETY - EVERYTHING RIDES ON IT**

The National Traffic Safety Administration (NHTSA) has published a brochure (DOT HS 809 361) that discusses all aspects of Tire Safety, as required by CFR 575.6. This brochure is reproduced in part below. It can be obtained and downloaded from NHTSA, free of charge, from the following web site:  
[http://www.nhtsa.dot.gov/cars/rules/TireSafety/ride\\_sonit/tires\\_index.html](http://www.nhtsa.dot.gov/cars/rules/TireSafety/ride_sonit/tires_index.html)

Studies of tire safety show that maintaining proper tire pressure, observing tire and vehicle load limits (not carrying more weight in your vehicle than your tires or vehicle can safely handle), avoiding road hazards, and inspecting tires for cuts, slashes, and other irregularities are the most important things you can do to avoid tire failure, such as tread separation or blowout and flat tires. These actions, along with other care and maintenance activities, can also:

- Improve vehicle handling
- Help protect you and others from avoidable breakdowns and accidents
- Improve fuel economy
- Increase the life of your tires.

This booklet presents a comprehensive overview of tire safety, including information on the following topics:

- Basic tire maintenance
- Uniform Tire Quality Grading System
- Fundamental characteristics of tires
- Tire safety tips.

Use this information to make tire safety a regular part of your vehicle maintenance routine. Recognize that the time you spend is minimal compared with the inconvenience and safety consequences of a flat tire or other tire failure.

### **1.5. SAFETY FIRST—BASIC TIRE MAINTENANCE**

Properly maintained tires improve the steering, stopping, traction, and load-carrying capability of your vehicle. Underinflated tires and overloaded vehicles are a major cause of tire failure. Therefore, as mentioned above, to avoid flat tires and other types of tire failure, you should maintain proper tire pressure, observe tire and vehicle load

limits, avoid road hazards, and regularly inspect your tires.

#### **1.5.1. FINDING YOUR VEHICLE'S RECOMMENDED TIRE PRESSURE AND LOAD LIMITS**

Tire information placards and vehicle certification labels contain information on tires and load limits. These labels indicate the vehicle manufacturer's information including:

- Recommended tire size
- Recommended tire inflation pressure
- Vehicle capacity weight (VCW—the maximum occupant and cargo weight a vehicle is designed to carry)
- Front and rear gross axle weight ratings (GAWR—the maximum weight the axle systems are designed to carry).

Both placards and certification labels are permanently attached to the trailer near the left front.

#### **1.5.2. UNDERSTANDING TIRE PRESSURE AND LOAD LIMITS**

Tire inflation pressure is the level of air in the tire that provides it with load-carrying capacity and affects the overall performance of the vehicle. The tire inflation pressure is a number that indicates the amount of air pressure—measured in pounds per square inch (psi)—a tire requires to be properly inflated. (You will also find this number on the vehicle information placard expressed in kilopascals (kpa), which is the metric measure used internationally.)

Manufacturers of passenger vehicles and light trucks determine this number based on the vehicle's design load limit, that is, the greatest amount of weight a vehicle can safely carry and the vehicle's tire size. The proper tire pressure for your vehicle is referred to as the "recommended cold inflation pressure." (As you will read below, it is difficult to obtain the recommended tire pressure if your tires are not cold.)

Because tires are designed to be used on more than one type of vehicle, tire manufacturers list the "maximum permissible inflation pressure" on the tire sidewall. This number is the greatest amount of air pressure that should ever be put in the tire under normal driving conditions.

#### **1.5.3. CHECKING TIRE PRESSURE**

It is important to check your vehicle's tire pressure at least once a month for the following reasons:

- Most tires may naturally lose air over time.
- Tires can lose air suddenly if you drive over a pothole or other object or if you strike the curb when parking.

- With radial tires, it is usually not possible to determine underinflation by visual inspection.

For convenience, purchase a tire pressure gauge to keep in your vehicle. Gauges can be purchased at tire dealerships, auto supply stores, and other retail outlets.

The recommended tire inflation pressure that vehicle manufacturers provide reflects the proper psi when a tire is cold. The term cold does not relate to the outside temperature. Rather, a cold tire is one that has not been driven on for at least three hours. When you drive, your tires get warmer, causing the air pressure within them to increase. Therefore, to get an accurate tire pressure reading, you must measure tire pressure when the tires are cold or compensate for the extra pressure in warm tires.

#### **1.5.4. STEPS FOR MAINTAINING PROPER TIRE PRESSURE**

- Step 1: Locate the recommended tire pressure on the vehicle's tire information placard, certification label, or in the owner's manual.
- Step 2: Record the tire pressure of all tires.
- Step 3: If the tire pressure is too high in any of the tires, slowly release air by gently pressing on the tire valve stem with the edge of your tire gauge until you get to the correct pressure.
- Step 4: If the tire pressure is too low, note the difference between the measured tire pressure and the correct tire pressure. These "missing" pounds of pressure are what you will need to add.
- Step 5: At a service station, add the missing pounds of air pressure to each tire that is underinflated.
- Step 6: Check all the tires to make sure they have the same air pressure (except in cases in which the front and rear tires are supposed to have different amounts of pressure).

If you have been driving your vehicle and think that a tire is underinflated, fill it to the recommended cold inflation pressure indicated on your vehicle's tire information placard or certification label. While your tire may still be slightly underinflated due to the extra pounds of pressure in the warm tire, it is safer to drive with air pressure that is slightly lower than the vehicle manufacturer's recommended cold inflation pressure than to drive with a significantly underinflated tire. Since this is a temporary fix, don't forget to recheck and adjust the tire's pressure when you can obtain a cold reading.

#### **1.5.5. TIRE SIZE**

To maintain tire safety, purchase new tires that are the same size as the vehicle's original tires or another size recommended by the manufacturer. Look at the tire information placard, the owner's manual, or the sidewall of the tire you are replacing to find this information. If you have any doubt about the correct size to choose, consult with the tire dealer.

#### **1.5.6. TIRE TREAD**

The tire tread provides the gripping action and traction that prevent your vehicle from slipping or sliding, especially when the road is wet or icy. In general, tires are not safe and should be replaced when the tread is worn down to 1/16 of an inch. Tires have built-in treadwear indicators that let you know when it is time to replace your tires. These indicators are raised sections spaced intermittently in the bottom of the tread grooves. When they appear "even" with the outside of the tread, it is time to replace your tires. Another method for checking tread depth is to place a penny in the tread with Lincoln's head upside down and facing you. If you can see the top of Lincoln's head, you are ready for new tires.

#### **1.5.7. TIRE BALANCE AND WHEEL ALIGNMENT**

To avoid vibration or shaking of the vehicle when a tire rotates, the tire must be properly balanced. This balance is achieved by positioning weights on the wheel to counterbalance heavy spots on the wheel-and-tire assembly. A wheel alignment adjusts the angles of the wheels so that they are positioned correctly relative to the vehicle's frame. This adjustment maximizes the life of your tires. These adjustments require special equipment and should be performed by a qualified technician.

#### **1.5.8. TIRE REPAIR**

The proper repair of a punctured tire requires a plug for the hole and a patch for the area inside the tire that surrounds the puncture hole. Punctures through the tread can be repaired if they are not too large, but punctures to the sidewall should not be repaired. Tires must be removed from the rim to be properly inspected before being plugged and patched.

#### **1.5.9. TIRE FUNDAMENTALS**

Federal law requires tire manufacturers to place standardized information on the sidewall of all tires. This information identifies and describes the fundamental characteristics of the tire and also provides a tire identification number for safety standard certification and in case of a recall.

### 1.5.9.1. Information on Passenger Vehicle Tires

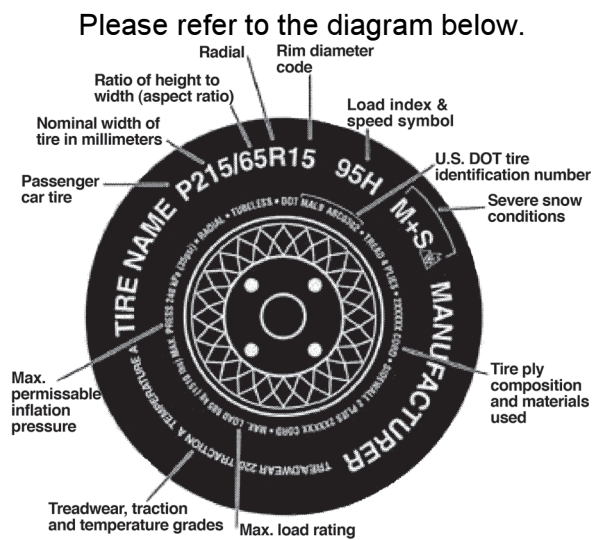

#### **P**

The "P" indicates the tire is for passenger vehicles.

#### **Next number**

This three-digit number gives the width in millimeters of the tire from sidewall edge to sidewall edge. In general, the larger the number, the wider the tire.

#### **Next number**

This two-digit number, known as the aspect ratio, gives the tire's ratio of height to width. Numbers of 70 or lower indicate a short sidewall for improved steering response and better overall handling on dry pavement.

#### **R**

The "R" stands for radial. Radial ply construction of tires has been the industry standard for the past 20 years.

#### **Next number**

This two-digit number is the wheel or rim diameter in inches. If you change your wheel size, you will have to purchase new tires to match the new wheel diameter.

#### **Next number**

This two- or three-digit number is the tire's load index. It is a measurement of how much weight each tire can support. You may find this information in your owner's manual. If not, contact a local tire dealer. Note: You may not find this information on all tires because it is not required by law.

#### **M+S**

The "M+S" or "M/S" indicates that the tire has some mud and snow capability. Most radial tires have these markings; hence, they have some mud and snow capability.

### **Speed Rating**

The speed rating denotes the speed at which a tire is designed to be driven for extended periods of time. The ratings range from 99 miles per hour (mph) to 186 mph. These ratings are listed below. Note: You may not find this information on all tires because it is not required by law.

Letter Rating	Speed Rating
Q	99 mph
R	106 mph
S	112 mph
T	118 mph
U	124 mph
H	130 mph
V	149 mph
W	168* mph
Y	186* mph

\* For tires with a maximum speed capability over 149 mph, tire manufacturers sometimes use the letters ZR. For those with a maximum speed capability over 186 mph, tire manufacturers always use the letters ZR.

### **U.S. DOT Tire Identification Number**

This begins with the letters "DOT" and indicates that the tire meets all federal standards. The next two numbers or letters are the plant code where it was manufactured, and the last four numbers represent the week and year the tire was built. For example, the numbers 3197 means the 31st week of 1997. The other numbers are marketing codes used at the manufacturer's discretion. This information is used to contact consumers if a tire defect requires a recall.

### **Tire Ply Composition and Materials Used**

The number of plies indicates the number of layers of rubber-coated fabric in the tire. In general, the greater the number of plies, the more weight a tire can support. Tire manufacturers also must indicate the materials in the tire, which include steel, nylon, polyester, and others.

### **Maximum Load Rating**

This number indicates the maximum load in kilograms and pounds that can be carried by the tire.

### **Maximum Permissible Inflation Pressure**

This number is the greatest amount of air pressure that should ever be put in the tire under normal driving conditions.

### 1.5.9.2. UTQGS Information

#### **Treadwear Number**

This number indicates the tire's wear rate. The higher the treadwear number is, the longer it should take for the tread to wear down. For

example, a tire graded 400 should last twice as long as a tire graded 200.

#### Traction Letter

This letter indicates a tire's ability to stop on wet pavement. A higher graded tire should allow you to stop your car on wet roads in a shorter distance than a tire with a lower grade. Traction is graded from highest to lowest as "AA", "A", "B", and "C".

#### Temperature Letter

This letter indicates a tire's resistance to heat. The temperature grade is for a tire that is inflated properly and not overloaded. Excessive speed, underinflation or excessive loading, either separately or in combination, can cause heat build-up and possible tire failure. From highest to lowest, a tire's resistance to heat is graded as "A", "B", or "C".

#### 1.5.9.3. Additional Information on Light Truck Tires

Please refer to the following diagram.

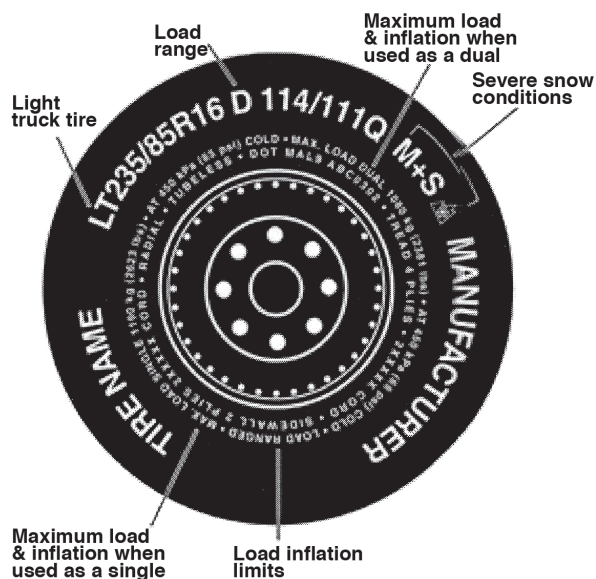

Tires for light trucks have other markings besides those found on the sidewalls of passenger tires.

#### LT

The "LT" indicates the tire is for light trucks or trailers.

#### ST

An "ST" is an indication the tire is for trailer use only.

#### Max. Load Dual kg (lbs) at kPa (psi) Cold

This information indicates the maximum load and tire pressure when the tire is used as a dual, that is, when four tires are put on each rear axle (a total of six or more tires on the vehicle).

#### Max. Load Single kg (lbs) at kPa (psi) Cold

This information indicates the maximum load and tire pressure when the tire is used as a single.

#### Load Range

This information identifies the tire's load-carrying capabilities and its inflation limits.

### 1.6. TIRE SAFETY TIPS

#### Preventing Tire Damage

- Slow down if you have to go over a pothole or other object in the road.
- Do not run over curbs or other foreign objects in the roadway, and try not to strike the curb when parking.

#### Tire Safety Checklist

- Check tire pressure regularly (at least once a month), including the spare.
- Inspect tires for uneven wear patterns on the tread, cracks, foreign objects, or other signs of wear or trauma.
- Remove bits of glass and foreign objects wedged in the tread.
- Make sure your tire valves have valve caps.
- Check tire pressure before going on a long trip.
- Do not overload your vehicle. Check the Tire Information and Loading Placard or User's Manual for the maximum recommended load for the vehicle.

# LIMITED WARRANTY

## HIGHWAY TIRE & WHEEL WARRANTY

**Carlisle Tire & Wheel Company** (“Carlisle”) warrants, subject to the terms, conditions and limitations stated herein, tires & wheels to be otherwise stated below.

**Carlisle’s liability for tires and wheels** shall be limited to replacement of any defective tire or wheel plus any applicable taxes, unless ment of any defective tire or wheel plus any applicable taxes, unless

### *Carlisle’s Warranty*

1. The Carlisle Tire & Wheel Warranty (“Warranty”) applies only to the original purchaser for two years from the date of purchase.
  - a) The warranty period for the coating of the wheel is ninety (90) days from the date of purchase.
2. First year 100% replacement for any Radial Trail, Ultra Sport Radial, Ultra CRT, USA Trail and Sport Trail tire for material or manufacturing defects. Including the cost of mounting and balancing.
  - a) Road hazards are included.
  - b) The defective tire will be replaced with comparable new tire.
3. 2nd year replacement warranty for any Radial Trail, Ultra Sport, Ultra CRT, USA Trail, and Sport Trail, for material or workmanship defects shall be replacement as long as not worn beyond the last 3/32” of usable tread.
  - a) Road hazards, mounting, and balancing are not included.
4. The Warranty does not cover incidental or consequential damages, including, but not limited to, lost time, inconvenience, loss of vehicle use, cost of towing or transportation, related property damage or consequential damages of any type or nature.
5. The Warranty is void if a covered tire is worn past last 3/32 of tread depth at any point on the tread contact surface.
6. The Warranty does not apply to the following:
  - a) repaired tubes, tires or wheels
  - b) tires or wheels used in racing and competition
  - c) tires or wheels subjected to road hazards, overloading, underinflation, improper mounting, fitment to incorrect rim, purposeful abuse or chemical contamination
  - d) tires or wheels which have been patched, unplugged or repaired or into which liquid balancers or sealants have been introduced
  - e) cosmetic irregularities
7. Carlisle makes no expressed claims of expected tire wear. Variables that affect tire wear are driving conditions, load and tire inflation pressure.

**To obtain warranty adjustments or warranty information** contact your Carlisle dealer or call Carlisle’s Product Services Department at **1-800-280-7959 (West Coast 1-800-367-5710) or fax to 1-800-352-0075**. Claims must be made within 30 days of discovery of defect. To obtain warranty info in Canada please call **1-800265-6155**.

THERE ARE NO WARRANTIES EITHER EXPRESSED OR IMPLIED, INCLUDING THE IMPLIED WARRANTIES OF MERCHANTABILITY AND FITNESS FOR A PARTICULAR PURPOSE, WHICH EXTEND BEYOND THE DESCRIPTION ON THE FACE HEREOF. CARLISLE SHALL NOT BE LIABLE FOR ANY INCIDENTAL OR CONSEQUENTIAL DAMAGES. NO REPRESENTATIVE OF CARLISLE TIRE & WHEEL COMPANY HAS AUTHORITY TO MAKE ANY REPRESENTATIONS OR PROMISES EXCEPT AS STATED HEREIN.

**Some states do not permit limitations** on the period of time an implied warranty lasts and do not permit the exclusion or limitation of incidental or consequential damages, thereof, the above limitations or exclusions may not apply. This warranty provides specified legal rights. Other rights may vary from state/province to state province.

*NOTE: All specifications subject to change without notice.*

#### **East Coast:**

Carlisle Tire & Wheel  
25 Windham Blvd.  
Aiken, South Carolina 29805  
1 800 260 7959

#### **Canada:**

Carlisle Tire & Wheel  
645 McMurry Rd.  
Waterloo, Ontario N2V2B7  
1 800 265 6155

#### **West Coast:**

Carlisle Tire & Wheel  
2233 E. Philadelphia St.  
Ontario, California 91761  
1 800 367 5710

# THE LOADSTAR

## WORRY FREE WARRANTY

### FOR HIGH SPEED TRAILER TIRES

### **Eligibility**

You are eligible for the benefits of this policy if you are the owner and original consumer of new LOADSTAR tires, bearing Dept. of Transportation prescribed tire identification numbers, only on the vehicle on which they were originally installed according to the vehicle manufacturer’s or LOADSTAR recommendations.

### **What is Warranted and for How Long**

Your tires are warranted against failures due to defective materials and workmanship.

- (A) Tires are eligible for warranty if presented not more than four years past manufacturing date and has a minimum of 2/32nd" tread remaining.
- (B) Free Replacement For (Bias or Bias/Belted) High Speed Trailer Tires. If a LOADSTAR tire fails due to defective materials or workmanship during the first 10 % of treadwear, or the first year, the tire will be replaced with a new comparable LOADSTAR tire without charge.
- (C) Treadwear Prorated Replacement. Tires not qualifying for free replacement will be replaced with a new, comparable tire based upon the percentage of tread that has been worn. The price you pay will equal the percentage of original, usable tread worn, multiplied by our then current “Predetermined Adjustment Price”. Owner pays mounting charge.

### **Definition of Comparable Tire**

A “comparable” new LOADSTAR tire may either be the same line of tire, or, in the event the disabled tire is out of production or unavailable, the same basic or equal construction and quality with different sidewall or treadwear configuration. If a higher priced tire is accepted as replacement, the difference in price will be paid by the owner.

### **Computing Treadwear**

Treadwear is computed as a percentage of the original, usable tread. The original, usable tread does not include the last 2/32nd inch of tread depth.

### **What is Not Covered By The Warranty**

- Failure due to fire, accident, malicious mischief, improper inflation, improper use, running flat, overloading or road hazards. Examples of road hazards include nails, glass and other foreign objects and natural and man-made defects or obstacles such as excavations, construction, potholes and chuckholes. Damages caused by road hazards include cuts, snags, punctures, scuffs, carcass bruises and impact breaks.
- Premature or irregular wear due to improper inflation or alignment or balance.
- Tires presented by other than the original consumer.

- Tires with weather cracking which were purchased more than (4) four years prior to presentation for adjustment. If you have no proof of purchase date, tires manufactured (4) four years prior to presentation are not covered.
- Loss of time, inconvenience, loss of use of the vehicle, costs of towing or transportation, or consequential damages of any type or nature.
- Any implied warranty, including merchantability or fitness, is limited to the duration of this written warranty or (4) years, whichever is less.
- Balancing or mounting charges.

\*NOTE: This limited warranty is the entire warranty given by LOADSTAR and LOADSTAR's complete obligation is as set forth herein. No one has authority to imply, suggest, agree, represent, warrant or promise contrary to the terms hereof.

### Owner's Obligation

You must present the tire to any LOADSTAR Tire Distributor or participating dealer in the U.S.A. To obtain no charge adjustment for tires, you must present proof of purchase date (such as trailer dealer or tire retailer invoice). You are responsible for payment of all taxes, as well as retailer charges for services that you request but are not covered by the warranty. This warranty gives you specific legal rights and you may also have other rights which vary from state to state.

### NOTE:

Some states do not allow the exclusion or limitation of incidental or consequential damage or how long an implied warranty lasts, so the limitations or exclusion may not apply to you.

### Adjustment Procedures

Unserviceable LOADSTAR tires adjustable under the terms of this policy should be returned to a LOADSTAR tire Distributor.

- 1.) Check National Distributor Directory for the nearest LOASTAR Tire Distributor. Call the nearest distributor. They can tell you where the nearest dealer would be located.
- 2.) Call 1-(800)-225-4714, 9AM-5PM weekdays for the nearest distributor.

### If There is No LOADSTAR Tire Dealer Available

- 1.) Purchase a tire of like quality and price.
- 2.) Return the LOADSTAR tire to the nearest distribution center, UPS. collect.
- 3.) IMPORTANT – **You Must** include the following:
  - A.) Invoice for replacement

- B.) Original invoice
- C.) Current information

Name: \_\_\_\_\_

Address: \_\_\_\_\_

Phone Number: \_\_\_\_\_

Date Tire Removed: \_\_\_\_\_

Reason Removed: \_\_\_\_\_

Trailer Make:                      Model :                      Year:

4.) Fill out this information and tape securely to the tire along with a mailing label addressed to the distributor.

5.) When the LOADSTAR Distributor receives the tire he will examine it, adjust it under the terms of the LOADSTAR warranty and send you a complete explanation and check (if applicable).

### Important Safety Information

Any tire, no matter how well constructed, may fail due to improper maintenance or service factors, creating a risk of property damage and serious or fatal injury. For your safety, comply with the following:

- 1.) Check air pressure monthly when tires are "cold". Use an accurate tire air pressure gauge. Do not reduce pressure when tires are hot. Proper inflation is essential. Underinflation produces flexing of sidewalls and builds up heat to the point that premature tire failure may occur. Overinflation can cause the tire to be more susceptible to impact damage.
- 2.) Never overload your tires. The maximum load capacity and maximum inflation pressure are molded into the sidewall of your tire. Overloading builds up excessive heat and can lead to early tire failure.
- 3.) Avoid damaging objects (chuckholes, glass, rocks, curbs, etc.) which may cause internal tire damage. Continued use of a tire that has suffered internal damage, which may not be visible externally, can lead to dangerous tire failure. Determination of internal damage will require dismounting of the tire and examination by trained tire personnel.
- 4.) Property damage and serious or fatal injury can also result from the following causes:
  - Improper tire mounting and inflation procedures may cause the tire beads to break with explosive force during installation of the tire on the rim. Tire and rim must match in size. Rim parts must match by manufacturer's design. Clean rim. Lubricate rim and beads. Do not exceed the maximum recommended pressure to seat the beads. **ONLY SPECIALLY TRAINED PERSONS SHOULD MOUNT TIRES.**
  - Use of worn out tires (less than 2/32nd" remaining tread depth) increases the probability of tire failure.
  - Excessive speed creates heat buildup in a tire, leading to possible tire failure.

# Towing Your Trailer

## Caution!

Check the following items each time before towing trailer.

1. Be sure all parts, bolts and nuts are tight.	6. Do not exceed trailer capacity.
2. Secure load to trailer with BIA approved tiedowns.	7. Be sure all lights are operating and are disconnected before backing into water.
3. Check tire pressure when tire is cold. Check and adjust wheel bearings if necessary after first 50 miles of use.	8. Coupling ball - make sure you are using the size marked on the trailer coupling and coupling must be securely latched to the ball.
4. Inspect and repack wheel bearings at least twice a year and before storing.	9. Cross safety chains under tongue and secure to towing vehicle.
5. Check that the Bed Locking Pin is in place.	10. Check brake operation.

## Launching

While you are waiting for your turn at the ramp, you should prepare your boat for launching. Attach a bow line to your boat and detach trailer tie-downs. If your boat is an outboard or stern drive, tilt up the lower unit. To avoid flooding and swamping your boat, before launching be sure the hull drain plug is in place and tight. **IMPORTANT: Unplug the wire harness before backing into the water.**

## Back Trailer to the Ramp

Have someone stand to one side of the ramp to direct you. Backing up a trailer can be tricky. A good way to simplify the procedure is to grasp the steering wheel with one hand at its lowest point (at 6 o'clock). When you want the trailer to go right, move your hand on the wheel to the right; to make the trailer go left, move your hand to the left.

## Launching

Back your trailer into the water until the front step of fender is at water level. This is a water level guide, which you can use on most ramps, however on extremely flat ramps you will want to back in further. On steeper ramps you will not want to back in as far. The other controlling factor is the style boat you have. Experimenting at this point will give you the best conditions for launching and loading your boat.

Set parking brake and gear shift. Unlock winch and push boat slowly but firmly off the trailer into the water. Be sure you (or your partner) have a firm hold on the bow line.

A more controlled launching can be achieved by letting you boat roll off the trailer with the winch rope attached. This is a slower process of unloading but is definitely more controlled.

## Loading your Boat

Again, back the trailer into the water following the same instructions as just stated for launching.

1. Prepare your boat for winching on the trailer. Bring your boat over to the trailer with the mooring rope. With the winch in the neutral lock position grab the winch rope and unwind the winch, Hook winch rope into eyelet on boat. Place winch latch into lock position for cranking boat on trailer. Winch slowly at first giving the boat time to swing around into position. This is necessary especially with a cross-current or cross wind. Crank boat completely onto trailer. Hook bow eye safety chain.
2. Some boaters prefer to drive their boats on the trailer. One thing to keep in mind is that you should not back into the water too deep. If you are in too deep the trailer loses all of its centering capabilities because your boat is floating on the water above the trailer. Loading your unit several times will give you a better feel for the depth to back your trailer in.

Drive your boat on carefully and try to hit the center of the trailer as much as possible. If you do not hit the center of the trailer, just keep slight pressure on the boat at slow throttle and drive the boat like you would a car. If you do not hit the center of the trailer, turn your boat so the front will go to the right, reverse the procedure if you are to the left of center. Keep turning until you feel the boat slide or drop into the center. Line the front of the boat up so it is headed right into the bow stop on the winch stand, adjusting it by turning the rear of your boat like a car.

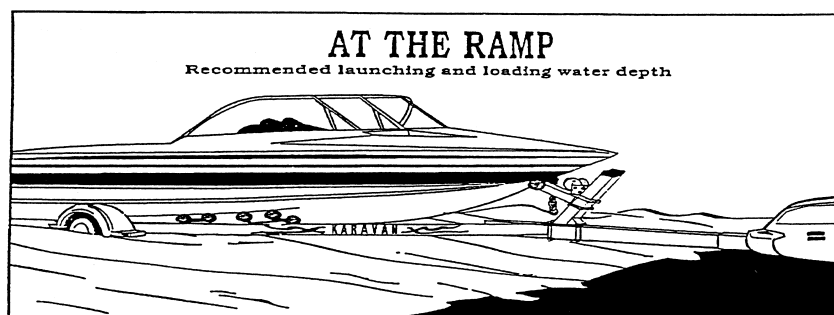

## DEALERS: GIVE THIS SHEET TO YOUR CUSTOMER IMPORTANT INFORMATION ON TOWING

**TOWING EQUIPMENT OWNERS:** Make sure all operators of your equipment read and understand this information before towing. Save for reference. This will help you properly select, use, and maintain your towing equipment. Refer to owner's manuals for your tow vehicle, trailer, and other parts of your towing system. Learn the capabilities and limitations of each part. **GROSS TRAILER WEIGHT** and **TONGUE WEIGHT** are two of the most important items to consider. **THESE WEIGHTS MUST NEVER EXCEED THE LOWEST RATING OF ANY PART OF YOUR TOWING SYSTEM.** **GROSS TRAILER WEIGHT** is the weight of the trailer plus all cargo. Measure **GROSS TRAILER WEIGHT** by putting the fully loaded trailer on a vehicle scale. **TONGUE WEIGHT** is the downward force exerted on the ball by the trailer coupler. Measure **TONGUE WEIGHT** with the fully loaded trailer on a level surface. The coupler must be at its normal towing height. Use a commercial scale or a bathroom scale. Set up the bathroom scale as shown for heavy tongue weights.

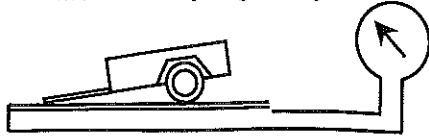

METHOD FOR MEASURING GROSS TRAILER WEIGHT

### YOUR TOWING EQUIPMENT

#### TRAILER HITCHES, RECEIVERS, AND BALL MOUNTS

Select these products by their gross trailer weight and tongue weight ratings. Match the products according to the anticipated use. Use only those products designed for your vehicle.

#### HITCH BALLS

Select by gross trailer weight rating, mounting platform thickness and hole size, and coupler socket size. Do not mix one class of hitch ball with another class of coupler. Platform must be at least 3/8 inch thick. Hole must not exceed threaded shank diameter by more than 1/16 inch. Use lock washer. Tighten per instructions. When tightened, shank must protrude beyond bottom of nut. Gross trailer weight rating and ball diameter are marked on hitch balls.

#### TRAILER COUPLERS

The coupler socket should be smooth, clean, and lightly lubricated. Tighten or adjust per coupler manufacturer's instructions. Use proper class type.

#### SAFETY CHAINS

Connect safety chains properly **EVERY TIME YOU TOW**. Cross chains under coupler. This is done to cradle the trailer tongue in the event the ball and coupler separate. Attach securely to the hitch or tow vehicle so they can't bounce loose. Leave only enough slack to permit full turning. Too much slack may prevent chains from maintaining control if other connections separate. Don't let chains drag on the road to avoid chain degradation.

#### TRAILER LIGHTS, TURN SIGNALS, ELECTRIC BRAKES, AND BREAK AWAY SWITCH CONNECTIONS

Make these safety-critical connections **EVERY TIME YOU TOW**, no matter how short the trip. Check operation, including electric brake manual control, before getting on the road.

#### SWAY CONTROLS

Sway controls can lessen the effects of sudden maneuvers, wind gusts, and buffeting caused by other vehicles. We recommend them for trailers with large surface areas, such as travel trailers. Adjustable friction models can help control trailers with low tongue weight. Recommended tongue weight is 10% of gross trailer weight.

#### OTHER USEFUL EQUIPMENT

AIR SPRINGS, AIR SHOCKS, or HELPER SPRINGS are useful for some hitch applications. A TRANSMISSION COOLER may be necessary for heavy towing. Many states require TOWING MIRRORS on both sides.

#### TIRE INFLATION

Check often. Follow tow vehicle and trailer manufacturers' recommendations. Improper tire inflation can cause uncontrollable trailer sway.

#### CHECK YOUR EQUIPMENT / REPLACE WORN PARTS

Check ball, coupler, chains, retaining pins and clips, and all other connectors **EVERY TIME YOU TOW**. Re-check at fuel and rest stops.

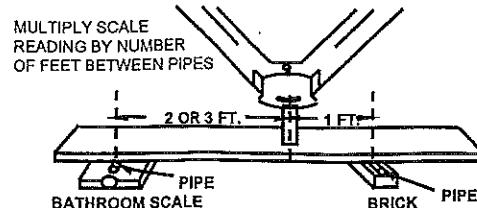

METHOD FOR MEASURING TRAILER TONGUE WEIGHT

### SAFE TOWING TIPS

#### NO PASSENGERS IN TRAILERS!

Never allow people in trailers while towing, under any circumstances.

#### TRAILER LOADING

Proper loading helps prevent sway. Place heavy object on the floor ahead of the axle. Balance the load side-to-side. Secure it to prevent shifting. Tongue weight should be 10-15 percent of gross weight for most trailers. Too low a percentage of tongue weight can cause sway. **NEVER** load the trailer rear-heavy. **LOAD THE TRAILER HEAVIER IN FRONT.**

#### DRIVING

The additional weight of a trailer affects acceleration, braking and handling. Allow extra time for passing, stopping, and changing lanes. Severe bumps can damage your towing vehicle, hitch, and trailer. Drive slowly on rough roads. **STOP AND MAKE A THOROUGH INSPECTION IF ANY PART OF YOUR TOWING SYSTEM STRIKES THE ROAD. CORRECT ANY PROBLEMS AND REPLACE ANY DAMAGED PARTS BEFORE RESUMING TRAVEL.**

#### CHECK FOR EXCESSIVE SWAY AND ELIMINATE IT

Excessive sway can lead to loss of control. Sway motion should settle out quickly. Sway tends to increase on a downgrade. Starting slowly, increase speed in gradual steps. If sway occurs, adjust your trailer load and equipment. Repeat until the trailer is stable at highway speed. Do this whenever your trailer loading changes.

#### IF TRAILER SUDDENLY STARTS TO SWAY

Turbulence from another vehicle, a wind gust, or a downgrade can cause sudden sway. So can a shift of the trailer's load or a trailer tire blowout. **IF THE TRAILER SWAYS, IT IS THE DRIVER'S RESPONSIBILITY TO ASSESS THE SITUATION AND TAKE APPROPRIATE ACTION.** Below are suggestions that may apply, depending on conditions:

#### DO

- Reduce your speed gradually.
- Hold the steering wheel as steady as possible.
- If your trailer has electric brakes, apply the brakes alone, without using the tow vehicle's brakes.

#### DON'T

- Don't hit your brake pedal hard unless absolutely necessary. A "jackknife" can result.
- Don't try to steer out of the sway condition. Sudden or violent steering can make it worse.
- Don't speed up. Sway increases as you go faster.
- Don't continue towing a trailer that tends to sway. You may lose control during an emergency maneuver or if the conditions listed above occur.

## DANGER

DO NOT MODIFY PRODUCT. TOWING VEHICLE MUST BE IN GOOD CONDITION. USE ONLY FOR TRAILER TOWING AND/OR ATTACHMENT OF TOWING PRODUCTS INC. ACCESSORIES. DO NOT EXTEND ORIGINAL STRUCTURE. DO NOT TOW ONE TRAILER BEHIND ANOTHER, WHICH MAY CAUSE LOSS OF CONTROL. FAILURE TO HEED WARNINGS AND FOLLOW INSTRUCTIONS MAY RESULT IN SERIOUS PERSONAL INJURY OR DEATH, VEHICLE CRASH, AND/OR PROPERTY DAMAGE.

## DON'T OVERLOAD ANY PART OF YOUR TOWING SYSTEM



### Read, Understand, Follow and Save These Instructions

- Read, understand and follow all instructions before installing and using this product. Never allow anyone unfamiliar with these instructions to use this product.
- Read, understand and follow all instructions provided by the manufacturer of the product(s) on which this product will be installed.
- Installation of this product must conform to the following mounting instructions.
- Save these instructions for use as a reference in the future.

### ⚠ WARNING

Failure to follow these warnings and instructions may result in property damage, serious bodily injury, and/or death.



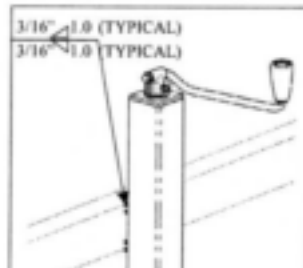
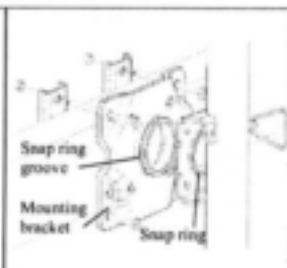
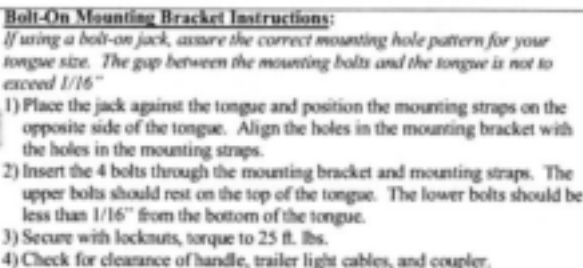
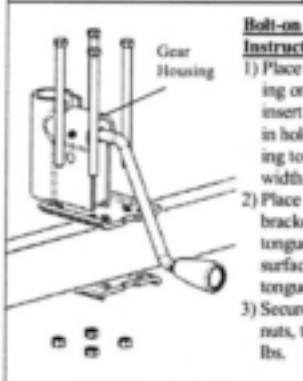
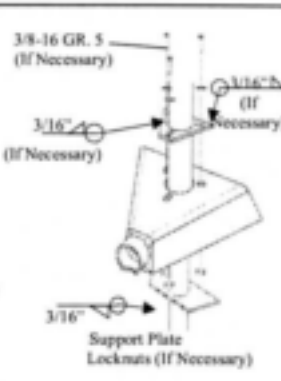

- Purchaser/owner must ensure that product is installed according to these instructions. Purchaser/owner must not alter or modify product.
- Operator and bystanders should never position any part of body under any portion of this product or the load being supported.
- Fully retract and rotate jack before towing.
- When using the drop foot or drop leg, make certain the supplied pin is fully inserted through both sides of the inner tube and the drop tube before using the jack.
- If using optional drop foot or caster, always remove drop foot or caster before towing to maximize ground clearance.
- This product is not intended to be used as a transport device for the implement it is attached to. Minimize movement of implement while jack is under load.
- Do not allow children to play on or around this product or the load being supported.
- Secure the load, vehicle and trailer from rolling (by blocking wheels) when operating jack or coupling trailer.
- Jack capacity is limited to the lesser of the jack, footplate, or caster wheel capacity.
- Never exceed maximum rated capacity. Refer to stamped markings or decals on product to obtain rated capacity. If uncertain, contact Cequent Trailer Products at 800-604-9466 or [www.cequentgroup.com](http://www.cequentgroup.com).
- These jacks are designed for vertical loading. Excessive side forces may cause jack failure and must be avoided.
- Before manually moving trailer, crank to lowest position.
- If this product has a pivot tube mount, make certain the pivot pin is fully inserted through both sides on the pivot tube and the pivot mount.
- If this product is a swivel jack, lock the plunger pin into a hole in the mounting bracket before raising or lowering the tongue.
- Before installing the snap ring, inspect the snap ring groove and remove any debris. Seat the snap ring fully into the groove.
- Do not attempt to weld "Bolt-On" brackets or straps to the tongue. Special brackets are available for "Weld-On" applications.
- If this product has a drop foot or drop leg, never attempt to adjust the drop foot or drop leg when there is any load on the jack.
- If this product is a rack jack, do not raise the gear housing above inner tube.
- These jacks are not designed for mounting to round tongues.
- All welding must be performed by an AWS certified welder.
- Always replace bent, broken, or worn parts before using this product.

### Installation Instructions

Before mounting the jack confirm that there will be no interference from the tow vehicle, tongue, ground, and any other mounted accessories while stationary or in motion. Before installing, check for interference in all positions including handle swing and swivel positions if applicable. Check for interference again after installation is complete.

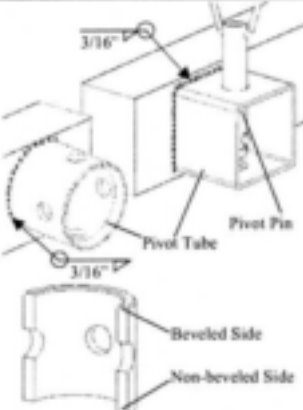
 <p><b>Direct-Mount:</b> The same welding instructions apply to other weld-on mounts.</p> <ol style="list-style-type: none"> <li>1) All welding must be performed by an AWS certified welder.</li> <li>2) Place the jack at the desired location. Weld 1" in 2 locations on both sides of the jack using a 3/16" fillet weld.</li> </ol>	 <p><b>Bolt-On Mounting Bracket Instructions:</b> If using a bolt-on jack, assure the correct mounting hole pattern for your tongue size. The gap between the mounting bolts and the tongue is not to exceed 1/16".</p> <ol style="list-style-type: none"> <li>1) Place the jack against the tongue and position the mounting straps on the opposite side of the tongue. Align the holes in the mounting bracket with the holes in the mounting straps.</li> <li>2) Insert the 4 bolts through the mounting bracket and mounting straps. The upper bolts should rest on the top of the tongue. The lower bolts should be less than 1/16" from the bottom of the tongue.</li> <li>3) Secure with locknuts, torque to 25 ft. lbs.</li> <li>4) Check for clearance of handle, trailer light cables, and coupler.</li> </ol>	 <p><b>Snap Ring/Bolt-Thru Instructions:</b></p> <ol style="list-style-type: none"> <li>1) To attach a snap ring model jack, place the jack bracket over the mount and place the snap ring in the groove. Seat the snap ring fully into the groove.</li> <li>2) To attach a bolt-thru model jack, place the jack bracket into the recessed opening on the mount. Place the small end of bushing into the jack bracket and onto the bolt. Tighten locknut until there is little movement in the bushing. Note: The bolt should be installed between the trailer tongue and mount, the jack bracket will be held by the bushing between the locknut and the mount.</li> </ol>
 <p><b>Bolt-on Rack Jack Instructions:</b></p> <ol style="list-style-type: none"> <li>1) Place the gear housing on the tongue, insert supplied bolts in holes corresponding to the tongue width.</li> <li>2) Place the mounting bracket below the tongue with the flat surface against the tongue.</li> <li>3) Secure with locknuts, torque to 25 ft. lbs.</li> </ol>	<p><b>"A" Plate Mounting Instructions (Bolt-On or Weld-On):</b> A-plate jacks are designed for mounting to trailers with A-plate couplers. It is recommended to attach a bottom support plate to the bottom of the tongue.</p> <ol style="list-style-type: none"> <li>1) All welding must be performed by an AWS certified welder.</li> <li>2) If the "A" plate is separate from the jack, align the jack (and foot, if equipped) with the jack and coupler as desired before welding. Use a 3/16" fillet weld.</li> <li>3) Bolt the jack "A" plate to the coupler. Use three 3/8-16 grade 5 bolts with washers, torque to 15-20 ft. lbs.</li> <li>4) Weld the recommended support plate to the bottom of the trailer frame. Use a 3/16" fillet weld.</li> <li>5) If your jack is a plain mount type, it may be mounted directly to a coupler with a 3/16" fillet weld. Align the foot (with the jack and coupler) as desired before welding.</li> <li>6) Rack jacks with a similar "A" plate incorporated into their design may be attached according to these instructions.</li> </ol>	 <p>Support Plate Locknuts (If Necessary)</p>

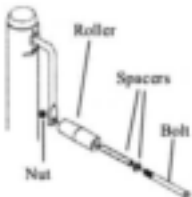
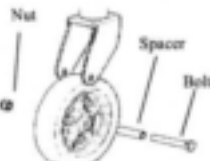
## Installation Instructions (Cont.)

 <p><b>Weld-on Pivot Tube Mounting Instructions (Round and Square Pivot Tubes):</b></p> <ol style="list-style-type: none"> <li>1) All welding must be performed by an AWS certified welder.</li> <li>2) The non-beveled side of the pivot tube is welded to the tongue unless otherwise specified on hardware.</li> <li>3) Place the weld-on pivot tube against the tongue and weld all around with a 3/16" fillet weld. Align one set of pivot mount holes vertically.</li> <li>4) Mate the jack to the pivot tube and secure with the supplied pin.</li> </ol>	 <p style="text-align: center;">Drop Foot</p> <p style="text-align: center;">Removable Caster</p> <p style="text-align: center;">Plunger Pin</p> <p style="text-align: center;">Foot Plate</p>	<p><b>To attach a handle assembly:</b></p> <ol style="list-style-type: none"> <li>1) Insert the long spacer into the roller followed by the thin spacer and the bolt.</li> <li>2) Secure to the crank stem with the nut provided.</li> </ol> 	<p><b>To attach a wheel assembly:</b></p> <ol style="list-style-type: none"> <li>1) Insert the long spacer into the wheel.</li> <li>2) Set the wheel into the caster body and place the bolt through the caster body and wheel.</li> <li>3) Secure with the nut provided.</li> </ol> 	<p><b>Heavy Duty Caster:</b></p> <ol style="list-style-type: none"> <li>1) Jack capacity limited to lesser of jack or caster.</li> <li>2) Use 4 3/8" bolts, washers, and lock-nuts as shown.</li> </ol> 
---	--	--	---	---

## Maintenance

The following procedures should be performed at least annually:

For side-wind models, the internal gearing and bushings of the jack must be kept lubricated. Apply a small amount of automotive grease to the internal gearing by removing the jack cover, or if equipped, use a needle nose applicator or standard grease gun on the lubrication point found on the side of the jack near the crank. Rotate the jack handle to distribute the grease evenly. A lightweight oil must be applied to the handle unit at both sides of the tube for side-wind models. If equipped, the axle bolt and nut assembly of the caster wheel must also be lubricated with the same light weight oil. For top-wind models, apply a lightweight oil to the screw stem. If this product is used in a marine environment, flush the jack assembly and bushings with fresh water, and apply fresh lubricant.

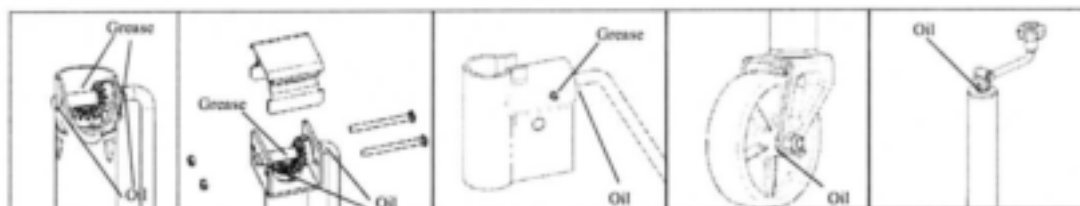

## How to Order

Use only Coquent Trailer Products' parts or parts of equal quality for repair. Replacement parts are available through Coquent Trailer Products' Customer Service Department, 715-693-1700 or 800-604-9466. Please specify product model number.

## Limited Three Year Warranty

**Warranty.** Coquent Trailer Products, Inc. ("We") warrants to the original consumer purchaser ("You") that the product will be free from defects in material and workmanship for a period of three years under normal use and service, ordinary wear and tear excepted. If the product does not comply with this warranty, We will replace the product without charge to You and within a reasonable time or, at Coquent's option, refund the purchase price. This warranty is not transferable.

**Limitations on the Warranty.** The warranty does not cover the following: (a) normal wear and tear; (b) damage through abuse, neglect, misuse, or as a result of any accident or in any other manner; (c) damage from misapplication, overloading, or improperly installed; (d) improper maintenance; (e) a product altered in any manner by anyone other than us.

**Obligations of Purchaser.** To make a claim, contact us at 1050 Indianhead Drive, Mosinee, WI, 1-800-604-9466, identify the product, and follow the instructions that will be provided. Any returned product that is replaced or refunded becomes the property of Coquent. You will be responsible for shipping costs to us. Please retain your purchase receipt to verify date of purchase. This must be produced to honor warranty claim.

**Remedy Limits.** Repair or replacement is the purchaser's sole remedy under this or any other warranty on the product, whether express or implied. We shall not be liable for service or labor charges incurred in removing or replacing a product or any incidental or consequential damages of any kind. We expressly disclaim any implied warranty of merchantability or fitness for particular purpose after the three-year warranty period. Some states do not allow the exclusion of incidental or consequential damages or limitation of an implied warranty so the above exclusion and limitation may not apply to you.

**Legal Rights.** This warranty gives you specific legal rights, and You also may have other rights which vary from state to state. **ANY IMPLIED WARRANTY OF MERCHANTABILITY OR FITNESS FOR A PARTICULAR PURPOSE ON ANY PRODUCT SHALL BE LIMITED TO THREE YEARS FROM THE DATE OF RETAIL PURCHASE BY YOU.** Some states do not allow limitations on how long an implied warranty lasts, so the above limitation may not apply to You.

This warranty is governed by the laws of the United States of America and is void where prohibited.

**Coquent Trailer Products**  
 1050 Indianhead Dr., P.O. Box 8 Mosinee, WI 54455-0008  
 800/604-9466 715/693-1700 Fax 715/693-1799  
 TR-Sales@cequentgroup.com  
 www.cequentgroup.com

### **WARNING:**

Fishtailing caused from improper tongue weight on the tow vehicle hitch ball can cause loss of control of the tow vehicle and result in serious injury or property damage.

## **Weight Distribution**

Establishing a trailer with the proper GVWR is very important. But once that has been established and you have the load on the trailer it is equally important that you have the proper distribution of the weight on the trailer. By that we mean you should have 5 to 10% of the total weight of your loaded trailer on the hitch coupler which is called tongue weight. This should be checked when the tongue is parallel to the ground. A bathroom scale can be used to determine this, or go to a truck scale.

EXAMPLE: The gross vehicle weight of trailer and load is 2,000 pounds. The tongue weight should not be less than 100 pounds nor more than 200 lbs.

Too light of tongue weight can cause the trailer to “fishtail” (sway from side to side) as you travel down the highway. This creates excessive strains on the towing vehicle, hitch and also the trailer itself. It can very easily cause an accident. To adjust for too light tongue weight the axle/axles must be moved backward on the trailer allowing more weight to be carried on the tongue. This is accomplished by loosening the U-bolts on most models. Adjustments should be made until the tongue weight falls within the 5 to 10% recommended range.

If only a slight weight adjustment is required it's possible you may be able to move gear to compensate the difference. Some towing vehicles require less tongue weight than others.

The 5 to 10% guide lines will hold quite true to form until you get into larger size loads anywhere from 4,000 pounds on up. At this point it becomes necessary to strike a happy medium of sufficient tongue weight to tow properly and yet not too much tongue weight as to create undue stress on the towing vehicle, hitch and hitch coupler. Check hitch rating to be sure of it's capacity or when buying a hitch make sure it will carry the load.

The weight-distribution hitch may be recommended to you by the dealer for heavier units. If this type system is installed all responsibilities will become those of the owner of the unit, not those of Karavan Trailers, Inc.

Listed are several items you must consider should you install this type system.

First off, make sure they are installed properly.

Care should be used so that they are not overloaded to the point the undue strain is applied to both the trailer and towing vehicle. This type system dampens the action of the surge hydraulic brake systems thus causing the brakes either not to be applied as soon as possible or may cause them to be partially applied at all times especially when being towed. This leads to overheated brakes plus excessive brake shoe wear. It may also lead to bearing failures because the heat build up will disintegrate the grease in the bearings.

## **Wheel Size**

Karavan uses different wheel sizes on its trailer line as listed in the chart below. Spare wheels may be purchased from Karavan dealer or else an automotive supply house with the given information. Read the numbers from the tire and count lug bolts to determine rim size.

Rim Size (inches)	No Of Studs	Bolt Circle Diameter (inches)	Common Automotive Rim
8	5	4-1/2	Ford, Chrysler
10	5	4-1/2	Ford, Chrysler
12	5	4-1/2	Ford, Chrysler
13	5	4-1/2	Ford, Chrysler
14	5	4-1/2	Ford, Chrysler
15	5 & 6	5-1/2	Ford, Chrysler
16	6		Ford, Chrysler
16.5 x 8	5	4-1/2	Ford, Chrysler

## **Winch and Winch Post Assembly for Boat Trailers**

The winch post assembly on your trailer is very easily adjusted up and down and front and rear on the trailer. Once the boat is positioned on the trailer as desired the winch post assembly should be adjusted so the rubber bow stop is located just above the bow eye on the boat. The rope, strap or cable will then run below the bow stop when loading and unloading the boat. When the boat is pulled on the trailer against the bow stop, the bow eye will be held securely directly under the bow stop, thus keeping your boat from moving forward or backward especially when the brakes are applied suddenly. Make sure the bow eye safety chain is hooked in the bow eye at all times except when loading or unloading.



# DLB 1500A BRAKE WINCH OPERATOR'S MANUAL

**WARNING** READ INSTRUCTIONS CAREFULLY BEFORE ATTEMPTING TO INSTALL, OPERATE OR SERVICE THIS WINCH. FAILURE TO COMPLY WITH INSTRUCTIONS COULD RESULT IN SERIOUS OR FATAL INJURY. RETAIN THESE INSTRUCTIONS FOR FUTURE REFERENCE.



## IMPORTANT SAFETY INFORMATION

- This brake winch is built for multi-purpose hauling and lifting operations. It is not to be used as a hoist for lifting, supporting or transporting people, or for loads over areas where people could be present.
- Respect this winch. High forces are created when using a winch, creating potential safety hazards. It should be operated and maintained in accordance with instructions. Never allow children or anyone who is not familiar with the operation of the winch to use it. A winch accident could result in personal injury.
- Check winch for proper operation on each use. Do not use if damaged. Seek immediate repairs.
- Never exceed rated capacity. Excess load may cause premature failure and could result in serious personal injury. This winch is rated on first layer of cable on the hub. Using more layers of cable increases the load on the winch.
- Never apply load on winch with cable fully extended. Keep at least three full turns of cable on the reel.
- Secure load properly. When winching operation is complete, do not depend on winch to support load.
- Operate with hand power only. This winch should not be operated with a motor of any kind. If the winch cannot be cranked easily with one hand, it is probably over-loaded.
- If winch will be used in freezing, icy conditions, apply silicone spray to ratchet pawl and spacer items T, U, V or W. Do not spray other brake mechanism parts.



**EC DECLARATION OF CONFORMITY** – Dutton-Lainson Company, Hastings, NE 68902-0729 U.S.A. manufactures and declares that the winch identified above fulfills all relevant provisions of the Directive 2006/42/EC. The technical file may be obtained from the persons listed.

Hastings, NE USA  
June 1, 2011

*Ron Haase*  
Senior Vice President  
Dutton-Lainson Company

Peter Munday  
Bainbridge International Limited  
8 Flanders Park, Hedge End, Southampton,  
Hampshire, SO30 2FZ UK

**ASSEMBLY** – Thread the handle onto the winch drive shaft and be certain that a clicking noise is produced when the handle is turned clockwise. Install the spring and locknut (Items K and L) on the end of the drive shaft as shown on parts drawing. These parts may appear to serve no function, but they provide several important fail-safe features, and should not be altered or removed.

**OPERATING INSTRUCTIONS** – Wind cable on winch reel by turning winch handle in clockwise direction. This should produce a loud, sharp, clicking noise. The load will remain in position when the handle is released. Wind cable off the winch reel by turning winch handle counterclockwise (no noise will be produced). The load will remain in position when the handle is released, but for extra security it is recommended that the handle be turned clockwise until at least two clicks are heard. This will add extra tightness to the brake mechanism. Always satisfy yourself that the winch is holding the load before releasing the winch handle.

**IMPORTANT:** Sufficient load must be applied to the cable to overcome internal resistance and operate the brake properly, otherwise turning the crank handle counterclockwise will only remove the handle from the shaft – the reel will not turn. The minimum operating load requirement is 75 lb (34 kg).

**NOT FOR THE MOVEMENT OF HUMAN BEINGS.**

**WINCH MAINTENANCE** – In order to insure maximum performance, a periodic inspection for any necessary preventive maintenance should be made. Check at least once annually and more frequently when the winch is exposed to an environment which is particularly dirty or wet. For continued smooth performance and increased life, occasionally grease gears, reel shaft and handle threads. An occasional drop of oil on the drive shaft bearings is also recommended. If winch will be used in freezing, icy conditions, apply silicone spray to ratchet pawl and spacer items T, U, V or W. **Note: Do not oil or grease brake mechanism items E and F.**

Keep winch in good working order. Damaged or severely-worn parts create unnecessary dangers and could result in personal injury or property damage.

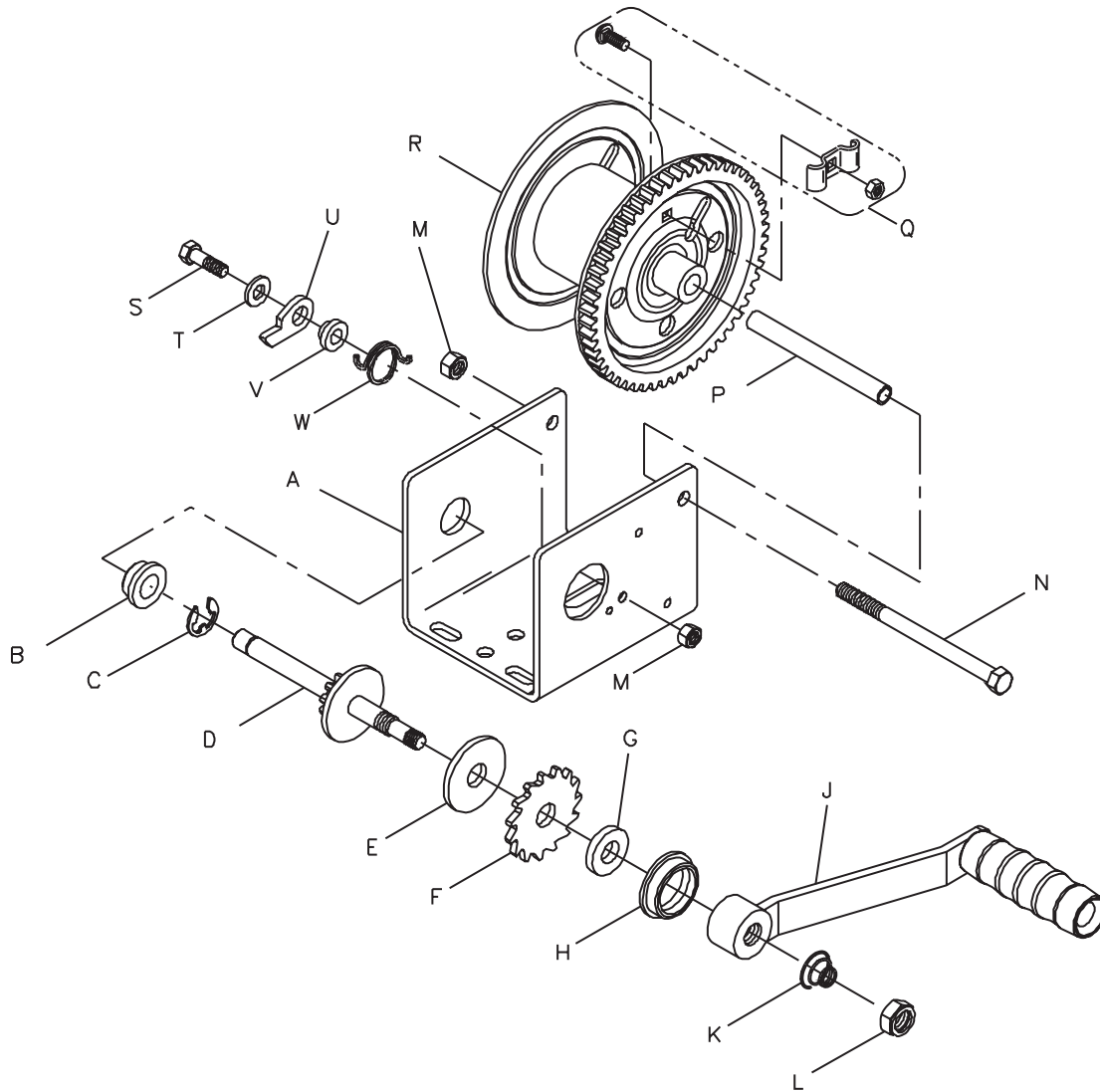

Ref.	Description	Part #
A	Winch Base	404891-PL
B	Shaft Bushing	204009
C	'E' Ring	205116
D	Drive Shaft	304760
E	Pressure Plate	204362
F	Ratchet Wheel	404164
G	Pressure Washer	404163

Ref.	Description	Part #
H	Shaft Bushing	206328
J	12" Handle	5703111
K	Handle Spring	204364
L	Handle Nut	205033
M	Locknut (3/8-16) (2)	204803
N	Reel Bolt	204804
P	Spacer (Reel)	204808

Ref.	Description	Part #
Q	Rope Clamp Kit	304221
R	Winch Reel	304755-PL
S	Ratchet Bolt	205167
T	Flat Washer	205055
U	Ratchet Pawl	404409
V	Ratchet Spacer	404166
W	Ratchet Spring	204363

To order replacement parts contact:

**Dutton-Lainson Company**  
 www.dlco.com  
 Tel: 800-569-6577  
 Fax: 402-460-4612  
 e-mail: DLsales@dutton-lainson.com

In Europe Contact:

**Bainbridge International Ltd.**  
 8 Flanders Park  
 Hedge End  
 Southampton  
 Hampshire, SO30 2FZ UK  
 Tel: +44 (0) 1489-776050  
 Fax: +44 (0) 1489-776055  
 www.bainbridgmarine.co.uk



A Dependable Company Since 1886  
**DUTTON-LAINSON COMPANY**

Hastings, NE 68902 U.S.A. • Tel 402-462-4141 • Fax 402-460-4612 • E-mail: dlsales@dlco.com • www.dutton-lainson.com

**ISO 9001:2008 REGISTERED Q.M.S.**

MADE IN  
 U.S.A.



# WINCH OPERATOR'S MANUAL

**WARNING** READ INSTRUCTIONS CAREFULLY BEFORE ATTEMPTING TO INSTALL, OPERATE OR SERVICE THIS WINCH. FAILURE TO COMPLY WITH INSTRUCTIONS COULD RESULT IN SERIOUS OR FATAL INJURY. RETAIN THESE INSTRUCTIONS FOR FUTURE REFERENCE.

## IMPORTANT SAFETY INFORMATION

- This winch is built for multi-purpose hauling and pulling operations. It is not recommended for lifting applications. For lifting, use a self-locking winch. DL winches are not to be used as hoists for lifting, supporting or transporting people, or for loads over areas where people could be present.
- Respect this winch. High forces are created when using a winch, creating potential safety hazards. It should be operated and maintained in accordance with instructions. Never allow children or anyone who is not familiar with the operation of the winch to use it.
- Maintain a firm grip on the winch handle at all times, and never release the handle when ratchet lever is in unlocked position with a load on the winch. Otherwise, handle will spin violently, which could cause personal injury.
- Check for proper ratchet operation on each use of the winch. Do not use if damaged. Seek immediate repairs.
- Never use the winch handle as a convenient handle for pulling or maneuvering the entire trailer or other equipment. Never pull on the winch handle against a locked ratchet.
- Never exceed rated capacity. Excess load may cause premature failure and could result in serious personal injury. This winch is rated with three layers of line on the hub. Using more layers of line or a large hub increases the load on the winch.
- Never apply load on winch with cable or rope fully extended. Keep at least three full turns of cable or rope on the reel.
- Secure load properly. When winching operation is complete, do not depend on winch to support load.
- Operate with hand power only. This winch should not be operated with a motor of any kind. If the winch cannot be cranked easily with one hand, it is probably over-loaded.
- Keep strap in good condition and replace at first sign of damage. Replacement strap should have a strength rating of at least 50% greater than the winch capacity.

**CE** EC DECLARATION OF CONFORMITY – Dutton-Lainson Company, Hastings, NE 68902-0729 U.S.A. manufactures and declares that the winch identified above fulfills all relevant provisions of the Directive 2006/42/EC. The technical file may be obtained from the persons listed.

Hastings, NE USA  
June 1, 2011

*Ron Haase*  
Senior Vice President  
Dutton-Lainson Company

Peter Munday  
Bainbridge International Limited  
8 Flanders Park, Hedge End, Southampton,  
Hampshire, SO30 2FZ UK

### DL600A, DL1100A

**OPERATING INSTRUCTIONS** – HANDLE AND NUT MUST BE TIGHTENED AGAINST DRIVE SHAFT BEFORE OPERATING WINCH. Wind line on winch reel by turning winch handle in clockwise direction with ratchet lever in “on” position. The ratchet should produce a loud, sharp, clicking noise. Make sure that ratchet lever is in “on” position and holding load before winch handle is released. To unwind or reel out line, securely grip winch handle and apply force in clockwise direction so that ratchet lever can easily be moved to “off” position. Carefully turn handle in counterclockwise direction. Do not lose control.

### DL1402A, DL1602A, DL2102A

**OPERATING INSTRUCTIONS** – HANDLE AND NUT MUST BE TIGHTENED AGAINST DRIVE SHAFT BEFORE OPERATING WINCH. Wind line on winch reel by turning winch handle in clockwise direction with ratchet lever in up position. The ratchet should produce a loud, sharp clicking noise. Make sure that ratchet lever is in up position and holding load before winch handle is released. To unwind or reel out line, securely grip winch handle and apply force in clockwise direction so that ratchet lever can easily be moved to down position. Carefully turn handle in counterclockwise direction. Do not lose control. The winch can be converted to wind line on to the underside of the reel. To do this, carefully examine ratchet assembly and remove it from winch. Do not lose small parts. Turn the lever over and reassemble. Do not over tighten bolt. Check operation to insure the ratchet lever rotates fully without binding.

### DL1800A, DL2000A, DL2500A, DL3200A

**OPERATING INSTRUCTIONS** – Attach winch handle securely to primary drive shaft (upper or low speed shaft). Make sure that handle clip engages with groove in drive shaft. Wind line on winch reel by turning winch handle in counterclockwise direction with ratchet lever in “down” position. The ratchet should produce a loud, sharp, clicking noise. Make sure that ratchet lever is in “down” position and holding load before winch handle is released. To unwind or reel out line, securely grip winch handle and apply force in counterclockwise direction so that ratchet lever can easily be moved to “up” position. Carefully turn handle in clockwise direction. Do not lose control. If handle is attached to intermediate (lower or high speed) shaft, operate as described above, reversing clockwise and counterclockwise. The winch can be converted to wind line on to the underside of the reel. To do this, carefully examine ratchet assembly and remove it from winch. Do not lose small parts. Turn the lever over and reassemble. Do not over tighten bolt. Check operation to insure the ratchet lever rotates fully without binding.

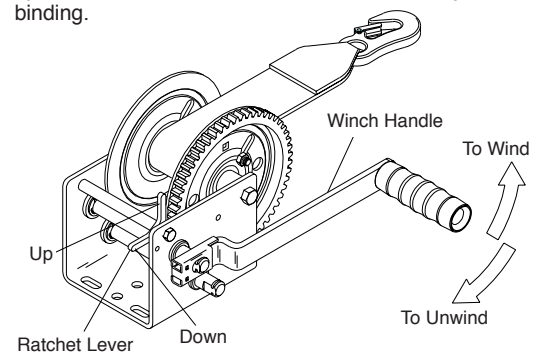
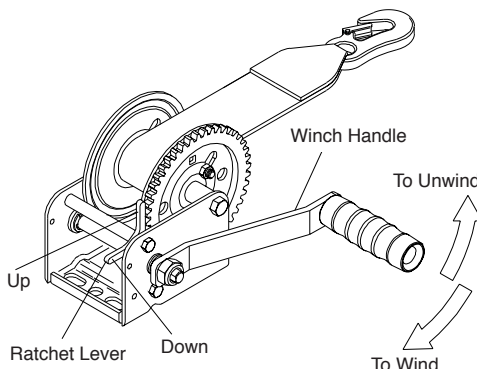
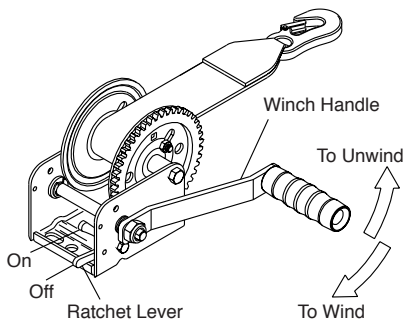

**WINCH MAINTENANCE** – This winch has been fully lubricated at the factory; but, for continued smooth performance and increased life, occasional greasing of gears and reel shaft and an occasional drop of oil on drive shaft bearings are recommended. Keep winch in good working order. Damaged or severely-worn parts create unnecessary dangers and could result in personal injury or property damage.

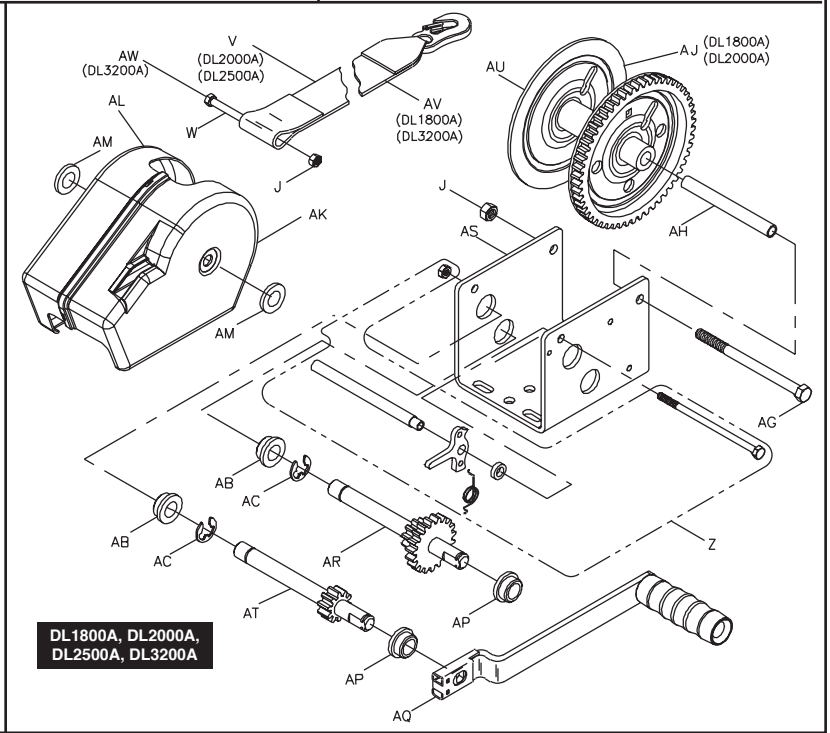
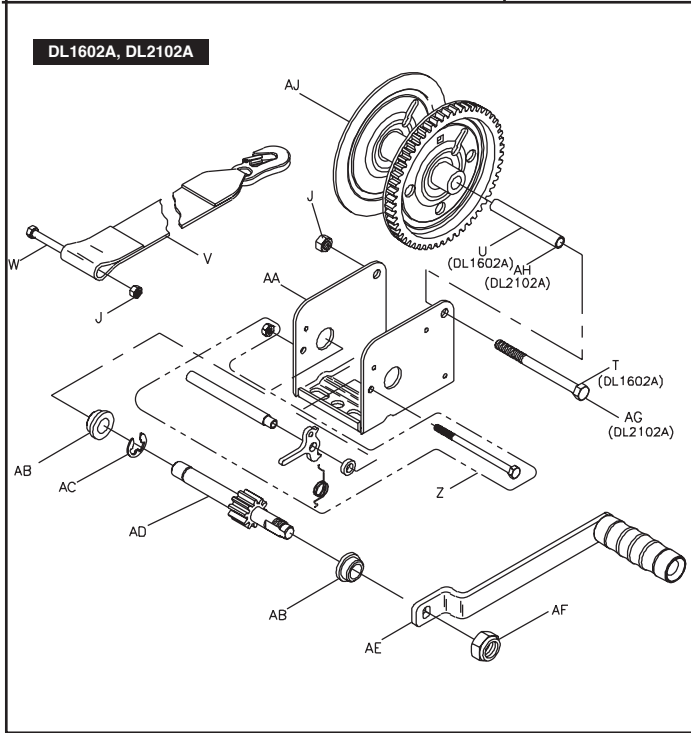
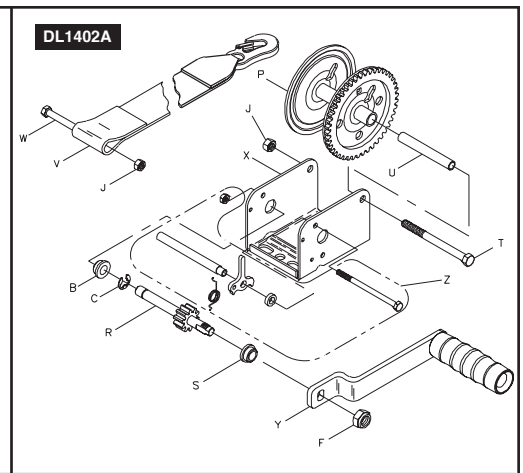
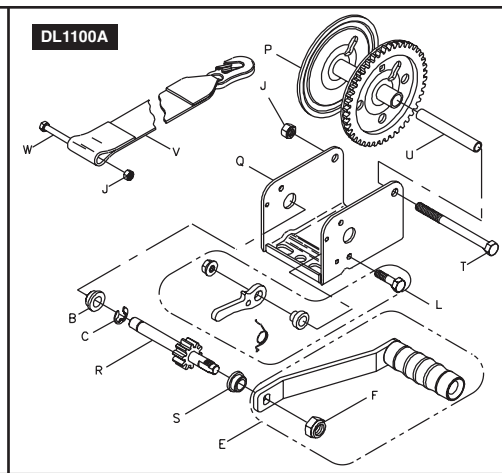
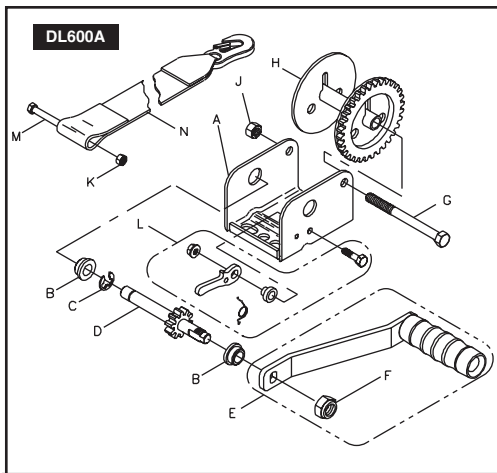

Ref.	Description	Part #
A	Base - DL600A	404882-PL
B	Bushing	204006
C	E-Ring	205012
D	Drive Shaft	304762
E	Handle 6" w/Nut	5703657
F	Locknut 1/2"	205015
G	Reel Shaft	204805
H	Reel (5/8" Hub) - DL600A	304721-PL
J	Locknut 3/8"	204803
K	Locknut 1/4"	205283
L	Ratchet Kit	5704531
M	Cap Screw 1/4 x 2-3/4	205281
N	Strap - DL600A - 15'	306112
N	Strap - DL600A - 12' PWC	306113
P	Reel (7/8" Hub) - DL1100A	304717-PL
P	Reel (7/8" Hub) (DL1402A)	304723-PL
Q	Base - DL1100A	404876-PL
R	Drive Shaft - DL1100A	304716
R	Drive Shaft (DL1402A)	304722
S	Bushing - (1402A)	204007
T	Reel Shaft - DL1100A	205144
T	Reel Shaft (1402A, 1602A)	203161

Ref.	Description	Part #
U	Spacer - DL1100A	206072
U	Spacer - (1402A, 1602A)	204807
V	Strap - (DL1100A thru DL2500A)	306114
W	Cap Screw - 3/8 x 3"	203366
X	Base - DL1402A	404870-PL
Y	Handle 6" - DL1402A	306116
Z	Ratchet Kit - (DL1402A & 1602A)	5704556
Z	Ratchet Kit - (DL1800A thru DL3200A)	5704754
AA	Base - DL1602A	404874-PL
AA	Base - DL2102A	406022-PL
AB	Bushing	204009
AC	E-Ring	205116
AD	Drive Shaft - DL1602A	304725
AD	Drive Shaft - DL2102A	304731
AE	Handle - 6" - (DL1602, 2102)	304998
AF	Locknut 5/8"	204809
AG	Reel Shaft - (DL1800A)	205127
AG	Reel Shaft - (DL2000A, 2102A, 2500A)	204804
AG	Reel Shaft - (DL3200A)	205335
AH	Spacer - (DL1800A thru 3200A)	204808
AJ	Reel - DL1602A	304724-PL
AJ	Reel - (DL2000A, 2102A, DL1800A)	304779-PL

Ref.	Description	Part #
AK	Cover (RT Half)	406055
AL	Cover (LF Half)	206475
AM	Spacer Washer	404916
AP	Bushing (DL1800A, DL2000A, 2500A, 3200A)	204012
AQ	Handle 8" (DL1800A, DL2000A, 2500A, 3200A)	304449
AR	Drive Shaft - DL1800A	304732
AR	Drive Shaft - DL2000A	304733
AR	Drive Shaft - DL2500A	304727
AR	Drive Shaft - DL3200A	304737
AS	Base - DL1800A	404879-PL
AS	Base - DL2000A	404880-PL
AS	Base - DL2500A	404875-PL
AS	Base - DL3200A	404907-PL
AT	Drive Shaft (DL2500A, 2000A, 1800A)	304726
AT	Drive Shaft - DL3200A	304736
AU	Reel - DL2500A	204782-PL
AU	Reel - DL3200A	304735-PL
AV	Strap - DL1800A - 20'	304429
AV	Strap - DL3200A - 20'	306115
AW	Cap Screw 3/8 x 3-1/4 - DL3200A	204904

To order replacement parts contact: **Dutton-Lainson Company** • www.dlco.com • Tel: 800-569-6577 • Fax: 402-460-4612 • e-mail: dlsales@dlco.com  
 In Europe Contact: **Bainbridge International Ltd.** • 8 Flanders Park • Hedge End, Southampton • Hampshire, SO30 2FZ UK • Tel: +44 (0) 1489-776050 •  
 Fax: +44 (0) 1489-776055 • www.bainbridgmarine.co.uk



**A Dependable Company Since 1886**  
**DUTTON-LAINSON COMPANY**

**MADE IN  
 U.S.A.**

Hastings, NE 68902 U.S.A. • Tel 402-462-4141 • Fax 402-460-4612 • E-mail: dlsales@dlco.com • www.dutton-lainson.com

**ISO 9001:2008 REGISTERED Q.M.S.**

# **Autoflex-Knott Limited Warranty**

## What Products Are Covered

All Autoflex-Knott trailer axles and suspensions.

## Limited 2 Year Warranty

Autoflex-Knott warrants to the original purchaser that its axles and suspension systems shall be free from defects in material and workmanship for a period of two (2) years from the date of first sale of the trailer incorporating such components.

## Limited 5 Year Warranty

Autoflex-Knott warrants to the original purchaser that its Compact bearings and the suspension components shall be free from defects in material and workmanship for a period of five (5) years from the date of first sale of the trailer incorporating such components.

## Exclusive Remedy

Autoflex-Knott will, at its option, repair or replace the affected components of any defective axle, repair or replace the entire defective axle, or refund the then-current list price of the axle. In all cases, a reasonable time period must be allowed for warranty repairs to be completed. Allowance will only be made for installation costs specifically approved by Autoflex-Knott.

## What You Must Do

In order to make a claim under these warranties:

1. You must be the original purchaser of the vehicle in which the Autoflex-Knott axles were originally installed.
2. You must promptly notify us within the warranty period of any defect, and provide us with the axle serial number and any substantiation which may include, but is not limited to, the return of part(s) that we may reasonably request.
3. The axles or suspensions must have been installed and maintained in accordance with good industry practice and any specific Autoflex-Knott recommendations.

## Exclusions

These warranties do not extend to or do not cover defects caused by:

1. The trailer wiring to the towing vehicle wiring.
2. The attachment of the running gear to the frame.
3. Hub imbalance, or any damage caused thereby.
4. Parts not supplied by Autoflex-Knott.
5. Any damage whatever caused by or related to any alteration of the axle including welding supplemental brackets to the axle.



6. Use of an axle on a unit other than the unit to which it was originally mounted.
7. Normal wear and tear.
8. Alignment
9. Improper installation.
10. Unreasonable use (including failure to prove reasonable and necessary maintenance, including required maintenance after „Prolonged Storage”)
11. Improper wheel nut torque.
12. Cosmetic finish or corrosion.

### Limitations

1. **In all cases, Autoflex-Knott reserves the right to fully satisfy its obligations under the Limited Warranties by refunding the then-current list price of the defective axle (or, if the axle has been discontinued, of the most nearly comparable current product).**
2. **Autoflex-Knott reserves the right to furnish a substitute or replacement component or product in the event an axle or any component of the axle is discontinued or is otherwise unavailable.**
3. **These warranties are nontransferable.**

### GENERAL

**THE FOREGOING WARRANTIES ARE EXCLUSIVE AND IN LIEU OF ALL OTHER WARRANTIES EXCEPT THAT OF TITLE, WHETHER WRITTEN , ORAL OR IMPLIED, IN FACT OR IN LAW (INCLUDING ANY WARRANTY OF MERCHANTABILITY OR FITNESS FOR A PARTICULAR PURPOSE).**

These warranties give you specific legal rights, and you may also have other rights which vary from state to state.

**THE DURATION OF ANY IMPLIED WARRANTIES, INCLUDING THE IMPLIED WARRANTIES OF MERCHANTABILITY AND FITNESS FOR A PARTICULAR PURPOSE, ARE LIMITED TO THE DURATION OF THE EXPRESS WARRANTIES HEREIN. AUTOFLEX-KNOTT HEREBY EXCLUDES INCIDENTAL AND CONSEQUENTIAL DAMAGES, INCLUDING LOSS OF TIME, INCONVENIENCE, LOSS OF USE, TOWING FEES, TELEPHONE CALLS OR COST OF MEALS, FOR ANY BREACH OF ANY EXPRESS OR IMPLIED WARRANTY, INCLUDING THE IMPLIED WARRANTIES OF MERCHANTABILITY AND FITNESS FOR A PARTICULAR PURPOSE.**

Some states do not allow limitations on how long an implied warranty lasts, or the exclusion or limitation of incidental or consequential damages, so the above exclusion or limitation may not apply to you.

Inquiries regarding these warranties should be sent to:

Autoflex-Knott Inc.  
P.O. Box: 45.  
100 Karavan Drive,  
Fox Lake, WI 53933

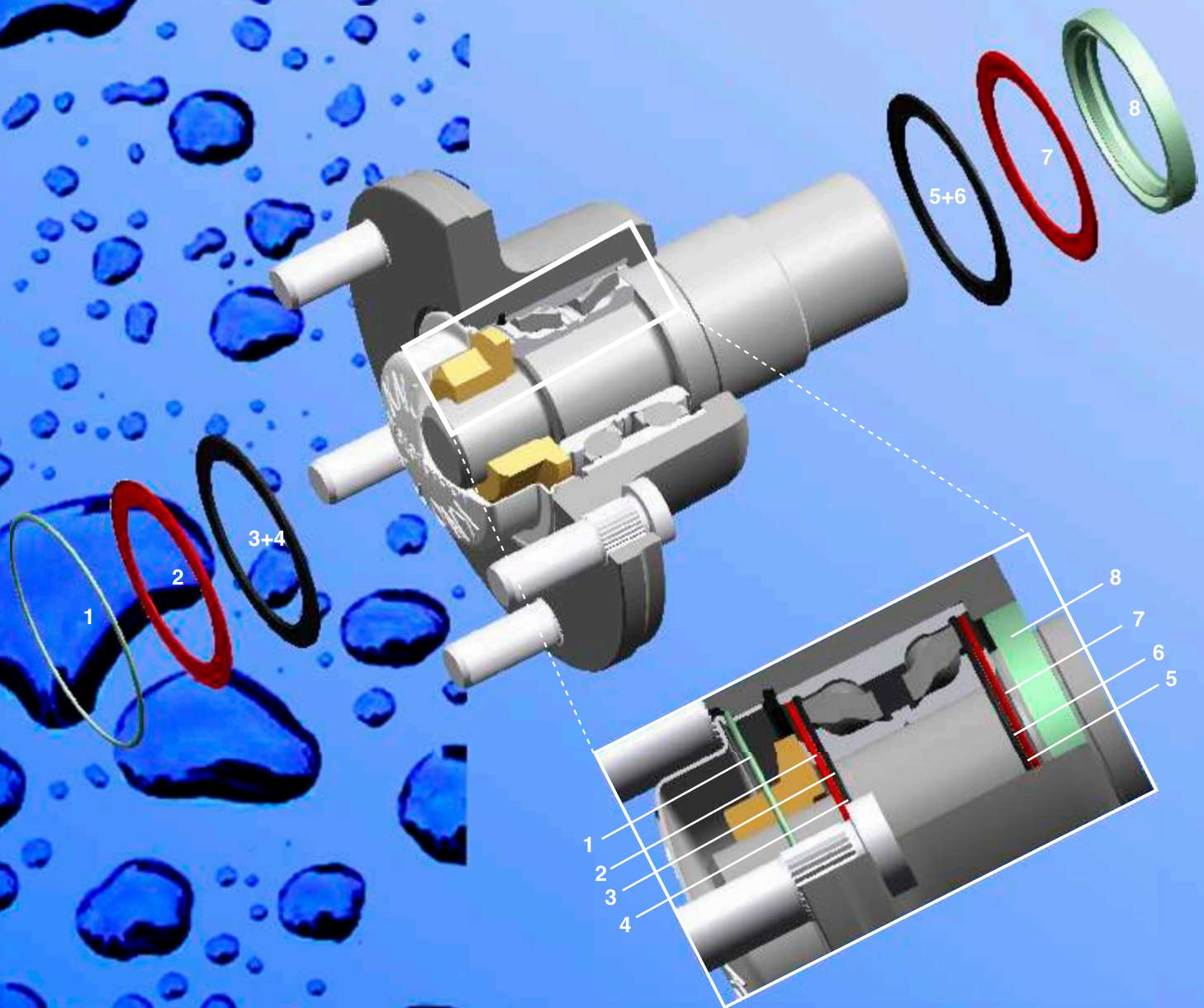

**Waterproof Areas:**

- 1 O-ring
- 2 External gasket with rotary shaft seal
- 3 Internal gasket with axial shaft seal
- 4 Internal gasket with rotary shaft seal
- 5 Internal gasket with rotary shaft seal
- 6 Internal gasket with axial shaft seal
- 7 External gasket with rotary shaft seal
- 8 Stainless steel rough edge sealing ring

**NEW!**

*The professional solution for your trailer!*

# WATERPROOF HUB

*with 8 watertight seals*

**D**

## KNOTT GMBH Werk Eggstätt

Obinger Straße 15, Postfach 20, 83125 Eggstätt  
Phone +49-8056-906-0, Fax +49-8056-906-103 Sales  
Fax +49-8056-906-106 Construction  
www.knott.de

## KNOTT GMBH Werk Regenstauf

Gutenbergstraße 21, 93128 Regenstauf  
Phone +49-9402-9317-0, Fax +49-9402-9317-99 Sales  
Fax +49-9402-9317-98 Logistics  
Fax +49-9402-9317-20 Spare parts  
Fax +49-9402-9317-96 Service  
www.knott.de

**USA**

## AUTOFLEX-KNOTT INC.

107 Industrial drive,  
Fox Lake WI 53933-0045  
Phone: +1 9209286875, Fax: +1 9209286880  
a.monti@autoflex.hu  
www.autoflex-knott.com

**RU**

## OOO Autoflex-KNOTT

142440 Moskovskaya obl.  
Noginskiy r-n, pos. Obuhovo  
Sosnoviy Bor  
Phone/Fax: +7 495 9613317  
www.autoflex.ru

**CHN**

## Ningbo Knott Trailer Components Co. Ltd

Sunjia, Shangtian Town, Fenghua,  
Ningbo City, Zhejiang Province  
Phone: +8613501735317  
paul@autoflex-knott.cn  
www.autoflex.hu

**SK**

## KOVOFLEX spol s.r.o.

Gorkého 25m P.O. Box 141  
929 01 Dunajská Streda  
závod: 930 01 Veľké Blahovo 441  
Phone: +421 315529022, Fax: +421 315527621  
kovoflex@kovoflex.sk  
www.kovoflex.sk

**RO**

## Autoflex Srl. Ro - 415500

Sos Aradului km 75,3  
3650 Salonta-Bihor  
Phone +40/259 373495, Fax +40/259 406748  
www.autoflex.ro

**RS**

## Autoflex-KNOTT YUG

Moše Pijade 153  
21220 Bečej  
Phone: +381 21 6915118, Fax: +381 21 6915993  
autoflex@stcable.co.rs  
www.autoflex.co.rs

**E**

## Autoflex-KNOTT Ibérica, S.L.

Polígono de Raos, parc, 12-G24  
39600 Maliano-Cantabria  
Phone: +34 942 369 187, Fax: +34 942 369 138  
autoflex@autoflexiberica.com  
www.autoflexiberica.com

**FI**

## AUTOFLEX-KNOTT OY

Iiveskuja 6  
FIN-01900 Nurmijärvi  
Phone +358 9 552250, Fax +358 9 552260  
teemu.frosen@autoflex.fi

## KNOTT waterproof Hub

**NEW!** for braked and unbraked axles  
Single axle trailer up to 1800 Kg  
Twin axle trailer up to 3500 Kg

- 3 waterproof seals each side of the bearing (directly on the bearing) (2 rotary and 1 axial)
- Leading edge seal between the hub and the axle collar (rough edge seal)
- Seal on the dust cap

Not just simple taper roller bearings  
Includes the totally maintenance free double row angular contact ball bearing, which has proven it's worth millions of times over the last 15 years.

- With double seal directly on both sides of the bearing
- Greased for life
- High performance grease with water resistant properties
- No bearing adjustment necessary
- Simply tighten the locking nuts to 280 Nm

# AUTÓFLEX-KNOTT KFT.

Tel.: (+36) 76/481-515, Fax: (+36) 76/481-494  
H-6000 Kecskemét Kadafalva-Heliport Pf.: 221.  
web: www.autoflex.hu e-mail: info@autoflex.hu

# Double row bearing with skew influence line

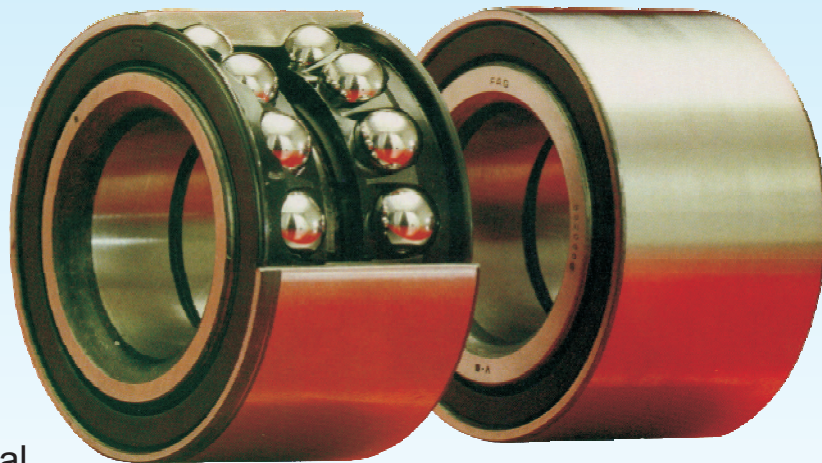

Spindle seal



Grease cap seal

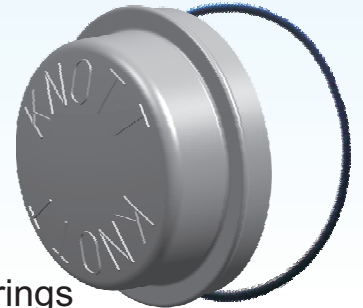

Heavy duty, maintenance free, water resistant bearings with double skew influence line are applied in our series production axles

Connecting to the mechanical characteristics, the skew influence line bearing with ball-row distance of .7" is equivalent to two pieces of bevel roller bearings with roller distance of 2.2"

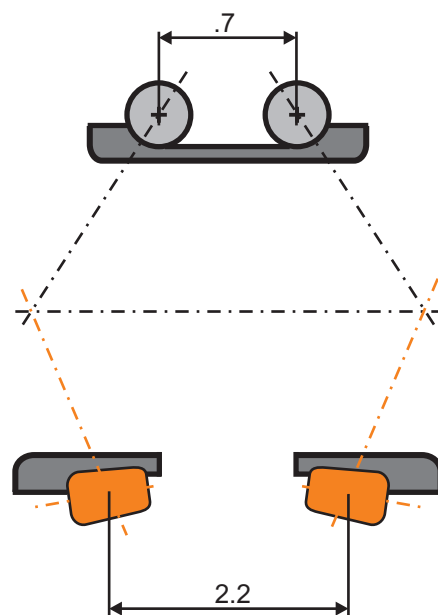



Affix  
First Class  
Stamp Here

**CARLISE TIRE REGISTRY**  
P.O. BOX 570  
AKRON, OHIO 44309

[www.carlisletire.com](http://www.carlisletire.com)

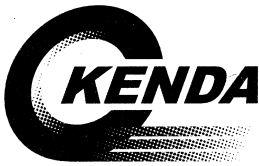

Affix  
First Class  
Stamp Here

SEND COMPLETED CARD TO:

**KENDA USA**  
7095 Americana Parkway  
Reynoldsburg, OH 43068-4118



PLACE  
STAMP  
HERE

**KARAVAN TRAILERS**  
P.O. BOX 27  
FOX LAKE, WISCONSIN 53933



**IMPORTANT: Federal Law requires the recording of this information.**  
*(Please Print)*

Dealer Name:	
Address:	
City:	
State, Zip Code:	
Date of Sale:	
Model Number:	
Trailer Identification No:	

**Please register your trailer online at [www.karavantrailers.com](http://www.karavantrailers.com)**

or send in your warranty card to Karavan Trailers, Inc., P.O. Box 27, Fox Lake, WI 53933.

**\*NOTE: Warrantanty card must be filled out completely and accurately or trailer will not be registered for warranty.**

**Retain This Part For Your Records**

**IMPORTANT: Federal Law requires the recording of this information.**  
*(Please Print)*

Dealer Name:	
Address:	
City:	
State, Zip Code:	
Date of Sale:	
Model Number:	
Trailer Identification No:	5KT _____
Tire Identification No:	Dot _____
	Dot _____
	Dot _____
	Dot _____
	Dot _____
	Dot _____
	Dot _____
	Dot _____

The "TIN" always begins with Dot and will be 10 to 12 digits long.

Customer Name:	
Address:	
City:	
State, Zip Code:	

**Owner Protection Service**

I, \_\_\_\_\_ (Purchaser of Trailer) Certify that I have received the maintenance and operating list of the above listed Karavan Trailer.