

KARAVAN P/N	SUPPLIER P/N	QTY. PER BOX	REQUIRES ISPM-15 COMPLIANT PALLET
214-00008-NA	XP10-1369	50	NO
214-00008(80)M-NA $\triangle 3$	XP10-1737	40	YES
214-00008(100)M-NA $\triangle 3$	XP10-1736	50	YES

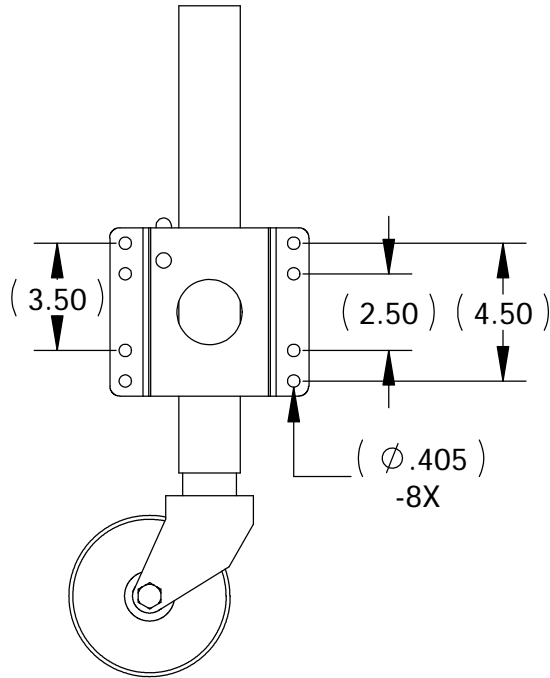

'MARK' LOCATIONS FOR SHIPPING PALLET WHEN REQUIRED TO BE ISPM-15 COMPLIANT

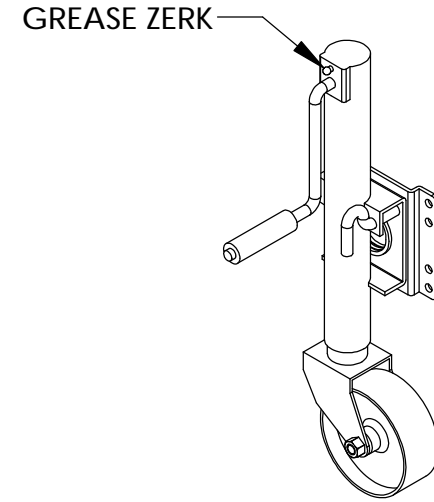
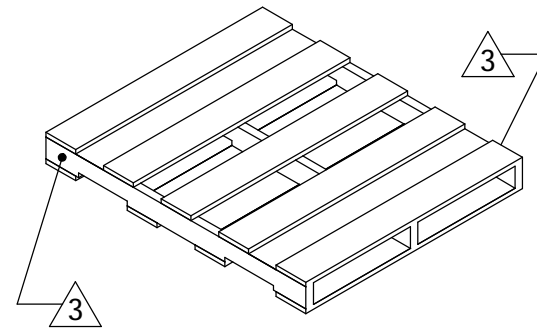

NOTES:

- 1.) CAPACITY: 1200#
- 2.) FINISH: ZP/ULTRASEAL.

$\triangle 3$ THESE PARTS ARE REQUIRED TO HAVE A PALLET THAT IS COMPLIANT TO THE LATEST ISPM-15 (INTERNATIONAL STANDARDS FOR PHYTOSANITARY MEASURES) AND BARE 'MARKING FOR APPROVED MEASURES' ON TWO VISABLE SURFACES, OPPISITE OF EACH OTHER.

DWG. REV.	ECR/NDR NUMBER	REVISED BY	DATE	DESCRIPTION
A/3	14079	RLR	05-15-07	CAPACITY WAS 1000#, ADDED GREASE ZERK.
A/2	13996	CPS	03-27-07	ADDED 214-00008(100)M-NA AND SUPPLIER TO PART NUMBER REFERENCE BLOCK

<p>ALL DIMENSIONS ARE IN INCHES UNLESS OTHERWISE STATED TOLERANCES EXCEPT AS NOTED DECIMALS: .X ±0.100 .XX ±0.060 .XXX ±0.030 .XXXX ±0.010 ANGLES: ±1° ALL FORMED ANGLES EQUAL 90° UNLESS NOTED OTHERWISE () INDICATES REFERENCE</p>	<p>THE INFORMATION IN THIS DRAWING IS THE SOLE PROPERTY OF KARAVAN TRAILERS, INC. ANY REPRODUCTION IN PART OR WHOLE WITHOUT THE WRITTEN PERMISSION OF KARAVAN TRAILERS, INC. IS PROHIBITED.</p>		
	<p>APPROVED BY: C~RICHTER</p>		<p>TITLE: TONGUE JACK (NO HARDWARE)</p>
	<p>DRAWN BY: Amy L. Thomas</p>	<p>DATE: 04-19-02</p>	<p>MAT'L: PURCHASED</p>
	<p>SHEET: 1 OF 1</p>	<p>SCALE: N/A</p>	<p>FINISH: N/A</p>
		<p>DWG. #: 214-00008</p>	